

Eversource New Hampshire Distribution System Assessment

5/28/2021

Prepared For:

Eversource Energy
780 N. Commercial Street
Manchester, NH, 03101

Prepared By:

TRC Companies
670 N. Commercial Street, Suite 203
Manchester, NH, 03101



TABLE OF CONTENTS

1. EXECUTIVE SUMMARYII

2. INTRODUCTION 1

 2.1 Project Background 1

 2.1.1 Prior Reliability-Focused Investments and Historical Performance 3

 2.2 Objectives of the Distribution System Assessment 6

 2.3 System Assessment Methodology 6

 2.4 Organization of the Distribution System Assessment 9

3. REVIEW OF INDUSTRY PRACTICES FOR RELIABILITY AND RESILIENCY INVESTMENT PLANNING 10

 3.1 Resiliency, Grid Hardening, and State interest in Integrated Distribution and Resilience Planning Initiatives 11

 3.2 Resiliency and Hardening Planning Frameworks 13

 3.3 Estimating Cost Effectiveness of Resilience 16

 3.4 Regulatory Review of Hardening Initiatives 17

 3.5 Implications for Eversource Hardening Activities 19

4. DISTRIBUTION SYSTEM AGE AND CONDITION ASSESSMENT20

 4.1 Pole and Equipment Age Analysis: 22

 4.1.1 Pole Loading Assessment of Existing Poles 23

 4.1.2 Pole Maintenance and Capital Programs 27

 4.1.3 Pole Assessment Summary and Recommendations 29

 4.2 Substation Transformers & Breakers 30

5. EVERSOURCE DISTRIBUTION SYSTEM ASSESSMENT PRACTICES, FINDINGS, AND RECOMMENDATIONS33

 5.1 Distribution Engineering Materials and Equipment 33

 5.1.1 Steel Poles 33

 5.1.2 Class 2 Wood Poles 39

 5.1.3 Spacer Cable 44

 5.1.4 Fiberglass Crossarms 52

 5.2 Vegetation Management 59

 5.3 Substation Transformers 80

 5.4 Distribution Planning 87

6. CONCLUSION AND SUMMARY OF RECOMMENDATIONS102

 6.1 Summary of Findings 102

 6.2 Recommendations 105

1. Executive Summary

Over the last eight years, The Public Service Company of New Hampshire d/b/a Eversource Energy (“Eversource” or the “Company”) has updated planning processes, enhanced standards, and increased investments aimed at improving system reliability for customers and hardening its distribution system for greater resiliency in light of increasingly recurring major weather events observed since at least 2008. These activities were highlighted in the Company’s 2019 Request for Permanent Rates, through which parties requested that Eversource better justify increased expenditures associated with these system resiliency investments.

TRC has conducted this distribution system assessment to satisfy the requirements of Section 11 of the Settlement Agreement filed between Eversource and parties in that rate filing, Docket DE 19-057. As part of this assessment, TRC has reviewed the use of the following materials and activities for reliability and resiliency improvements:

- Use of distribution-class steel poles as a standard in off-road right-of-way
- Use of Class 2 wood poles as a standard in road-side primary distribution lines
- Use of spacer cable as a standard for overhead conductor
- Use of fiberglass crossarms
- Planning methods for line relocation and reconductoring activities
- Vegetation management activities, including Enhanced Tree Trimming, Enhanced Tree Removal, and Right-Of-Way Clearing, in addition to Scheduled Maintenance Trimming
- Substation transformer and circuit breaker replacement processes

To assess these standards and practices, TRC reviewed Eversource’s current practices for each of the above topic areas and identified typical usage and installation procedures for equipment and materials. TRC surveyed industry research to identify common practices across peer utilities and develop a business case of the benefits for each engineering decision or activity. Finally, TRC conducted a cost analysis, where applicable, to identify lifecycle costs of proposed or alternative equipment or materials, factoring in upfront costs and ongoing maintenance and replacement costs, in addition to escalation over assets’ expected life. Based on these research activities, TRC proposed recommendations for future standards or activities within each topic area.

Additionally, TRC reviewed more broadly the current state of utility planning for resiliency and grid hardening measures around the country to identify trends or best practices for how peer utilities approach resiliency investments. This industry research, which included a literature review and expert interviews, found that utilities and regulators across multiple regions of the U.S. are renewing their interest and planning processes for resiliency both in reaction to recent severe weather events that cause widespread outages and in recognition of future risks anticipated due to climate change. Utilities in New York and Florida provide two templates for how to plan for and prioritize enhanced distribution system resiliency. In both cases, utilities have identified and prioritized the risks inherent to their distribution system architecture, developed tailored solutions to address those risks, estimated the costs, and implemented

resiliency measures to address those risks. Despite the increased planning and investment across the country, research and experts point to a lack of any accepted approach for determining cost effectiveness of resiliency investments. The severe events that grid hardening aims to guard against, low-frequency yet high-impact, make it difficult to measure how hardening mitigations may or may not perform.

TRC’s findings and recommendations relevant to each of the study topic areas are listed below:

Figure ES-1-1. Summary of Key Findings and Recommendations by Study Topic Area

Topic Area	Key Findings	Recommendations
System Condition	<ul style="list-style-type: none"> • The distribution system has many components that are beyond their expected life and require replacement to maintain system reliability and resiliency. • Substantial numbers of wood poles, circuits of primary conductor, substation breakers and substation transformers are at the end of life. • Wood poles are structurally overloaded due to their age and number of attachments. • Many circuit lines in the ROW are inaccessible due to location and difficult to maintain. • Trees and canopy are in close proximity to distribution system making the lines vulnerable to outages. 	<ul style="list-style-type: none"> • Accelerate replacement of aged equipment (poles, conductor, substation breakers & transformers), with a systematic plan (defined in sections 3 & 4) for each equipment type, based on system criticality and age. • Replace wood poles that are structurally overloaded 90% or more, with the properly sized poles in the next 10 years. • Identify candidate lines for relocation to roadside and develop 5-year plan to rebuild. • Increase vegetation management and spacer cable installation for vulnerable lines. • Consolidate current resiliency/hardening efforts into an overarching program following the decision framework outlined by the Department of Energy.
Steel Poles	<ul style="list-style-type: none"> • Benefits of steel poles include improved strength, reduced likelihood of catastrophic failure, and lower maintenance costs. • Steel poles have twice the expected useful life of an equivalent wood pole. 	<ul style="list-style-type: none"> • Given lower lifecycle costs and difficulty in patrolling and replacing remote right-of-way assets in the event of a failure, continue to use steel poles as the standard in these environments.

Topic Area	Key Findings	Recommendations
	<ul style="list-style-type: none"> While upfront costs are higher, the improved longevity of steel yields a lower total lifecycle cost compared to wood poles. 	<ul style="list-style-type: none"> Establish a proactive program to identify and replace five circuit miles/year of wood poles in the ROW with steel, in areas susceptible to damage or failure.
Class 2 Wood Poles	<ul style="list-style-type: none"> Class 2 wood poles can withstand 60% greater force than smaller-diameter class 4 poles, improving outcomes during tree strikes or high winds. Class 2 wood poles have marginally (2-4%) higher costs than equivalent Class 3 poles. At current failure rates, if 8-9 poles (~5%) did not fail due to use of stronger Class 2 poles, incremental costs would be negated. 	<ul style="list-style-type: none"> Continue use of Class 2 wood poles due to low additional costs and strength improvements in severe weather scenarios.
Spacer Cable	<ul style="list-style-type: none"> Spacer cable is the Eversource standard for new and rebuilt three phase distribution lines. Spacer cable is designed to reduce faults from tree and animal contacts and can survive larger tree strikes, compared to open-wire designs. Spacer cable is more compact, requiring less ROW clearance. Spacer cable is approximately double the cost of open wire. 	<ul style="list-style-type: none"> Follow the Eversource 2016 Resiliency Guidelines for spacer cable. Develop 5-year plan to replace open-wire circuits with spacer cable in vulnerable areas. Work in conjunction with the inaccessible line relocations to the roadside and steel pole installation projects.
Fiberglass Crossarms	<ul style="list-style-type: none"> Fiberglass crossarms are the Eversource standard for new and replacement crossarm construction. Fiberglass crossarms yield improved longevity, strength, material predictability, and installation compared to wood. Fiberglass crossarms pass the heaviest ice loading, heavy-tree contact, and high-wind simulations where wood crossarms failed. 	<ul style="list-style-type: none"> Continue to use fiberglass crossarms as specified. Lower lifecycle costs and improved strength in severe weather are main advantages.

Topic Area	Key Findings	Recommendations
	<ul style="list-style-type: none"> Fiberglass crossarms pair well with steel poles due to the extended lifecycle of both. Total lifecycle costs of fiberglass crossarms are 38-44% of the total for wood crossarms. 	
Vegetation Management	<ul style="list-style-type: none"> A portfolio approach to vegetation management (SMT, ETT, ETR, and ROW clearing) has led to reductions in tree related SAIFI and SAIDI scores, improving customer reliability. Inside-zone tree reliability metrics have improved dramatically over the last decade, while outside-zone metrics show a slight downward trend. Deferring scheduled maintenance cycles or reducing annual investments in vegetation management can lead to disproportionately negative impacts, as additional vegetation growth during those periods increases per-mile costs for management in the future and reduces the Company's ability to maintain regular cycles. 	<ul style="list-style-type: none"> For SMT, address an average 2,440 miles annually to follow the 60-month clearing cycle. Accelerate ETT to 80 miles per year to address the remaining 500 miles of the backbone circuits within the next seven years. Continue ROW clearing at the current pace to allow for the restoration of the full original easement where vegetation has encroached. For ETR, target approximately 19,000 hazard tree removals annually following the current identification and prioritization practice.
Substation Transformers	<ul style="list-style-type: none"> Standardizing substation transformer sizes can provide benefits for streamlining inventory and reducing event response time. 	<ul style="list-style-type: none"> Standardize substation transformer sizes wherever possible based on voltage class to allow for greater efficiency in maintaining stock of fewer transformer sizes and flexibility in responding to contingency events and coordination with neighboring state service areas. Continue to assess to determine when circuit breakers should be used in place of circuit switchers for operational and reliability benefits.

Topic Area	Key Findings	Recommendations
Distribution Planning	<ul style="list-style-type: none"> • Eversource conducts distribution planning to maintain system operations within established operating criteria. • Engineers develop solutions to address capacity, power quality, and reliability concerns based on historical performance data and forward-looking forecasts. • Line relocation and reconductoring are two options to address reliability issues. 	<ul style="list-style-type: none"> • Establish a tracking program to compare historical outage data for line segments for 3-5 years (as data is available) and then report annually on that segment post-improvement. Such a system will document the improved reliability and resiliency delivered by relocation and reconductoring projects. • Reduce the number of feeders without tie capability to allow for circuit reconfiguration and load pickup throughout the system. • Maintain awareness for distribution project cost increases that may arise as projects are delayed.

2. Introduction

This section provides a summary of the project's background and TRC's methodology for undertaking the study and associated engineering analysis.

2.1 Project Background

TRC conducted this distribution infrastructure condition assessment study to satisfy the requirements of Section 11 of the Settlement Agreement filed between Eversource and parties in Docket DE 19-057. Below is a summary of the regulatory history preceding the settlement agreement.

In Eversource's 2019 Request for Permanent Rates,¹ the Company identified a set of initiatives intended to improve the performance and resiliency of the distribution system. Like many electric utilities around the country², Eversource is increasing its capital spending for distribution system investments to add automation and replace aging or "substandard" equipment to maintain and improve reliability and to develop better system resiliency. At the time of the rate filing, most of Eversource's capital budget was directed toward investments in reliability improvements – nearly two-thirds of the \$137 million planned for 2019. As part of this capital plan, Eversource intended to address relocations of lines in rights-of-way, line reconstruction and equipment replacement, and asset condition replacements. The Company uses these replacement opportunities to increase the strength, intelligence, and resiliency capabilities of plant and assets, where an incremental benefit may be gained for the benefit of the system and does not simply replacing assets "like for like."

Although the Company has recorded improvements in the duration and number of customers experiencing outages as a result of its increased investments, Eversource has also experienced an increase in the number of outages at the same time. This trend is driven by both improved granularity of data, and an increase in significant weather events that cause widespread outages. Over the past 12 years, the Company has experienced five storm events with an impact to more than 40% of customers, including the 2008 ice storm, or an extreme event nearly every two years, on average. The recurrence of these weather events has prompted Eversource to revisit the materials composition, size, construction, and accessibility of overhead distribution poles, crossarms, circuits, and substation equipment. These strategies include:

- Use of Class 2 wooden poles in place of 40-foot class 4 poles for standard construction
- Use of light-duty steel poles in off-road rights-of-way

¹ Public Service Company of New Hampshire (Eversource), Testimony of Joseph A. Purington and Lee G. Lajoie - Docket No. DE 19-057, May 2019. https://www.puc.nh.gov/Regulatory/Docketbk/2019/19-057/INITIAL%20FILING%20-%20PETITION/19-057_2019-05-28_EVERSOURCE_DTESTIMONY_PURINGTON_LAJOIE.PDF

² See Chapter 3 of this report for a detailed look at industry trends relating to distribution system planning and investments for reliability and resiliency.

- Use of fiberglass cross-arms
- Reconstruction or relocation of older, 34.5-kV distribution lines in off-road rights-of-way
- Upgrades of undersized wire in off-road rights-of-way and use of covered conductor or spacer cable for off-road lines
- Upgrades of roadside three-phase lines by reconductoring, including use of spacer cable, stronger poles, and shorter spans
- Use of vacuum circuit breakers in place of oil circuit breakers in substations

Additionally, outside of the Company's capital distribution planning, Eversource conducts a range of vegetation management activities to maintain reliability of its system. Tree-related incidents are by far the leading cause of outages, 3 to 4 times greater than the next closest categories, as shown in Figure 5-22. These vegetation management activities include Scheduled Maintenance Trimming, Enhanced Tree Trimming, Full-width Right-of-Way Clearing, and Enhanced Hazard Tree Removal.

On top of these base activities, Eversource sought to obtain authorization for investments in resiliency and projects needed to prepare the grid for integration of future advanced energy solutions. Eversource referred to this incremental investment plan as the "Grid Transformation and Enablement Program" (GTEP), which was designed to enable accelerated asset replacements above the pace of the traditional, base capital plans described above. Following discussion with parties throughout the proceeding, Eversource withdrew the GTEP proposal for resubmission in a separate docket, outside of DE 19-057.

In response to Eversource's proposal, Commission staff raised concerns with several of the asset replacement and upgrade activities described in the base capital plan. Specifically, Staff indicated that Eversource had not properly demonstrated the need for these higher standards of investments or replacements of infrastructure.³

For both the pole and crossarm standards and right-of-way/reconductoring initiatives, Staff's view was that there was insufficient analysis or understanding of the value provided to customers through the proposed investments. To support the additional cost, a "cost-benefit analysis" or business case would be needed to quantify the benefits of such investments. For the substation oil circuit breaker replacement initiative, Staff's view was that the existing breakers have not reached the end of expected useful life or caused issues related to outages, environmental damage, or maintenance costs.

Staff also viewed metrics in relation to current and proposed vegetation management practices. Eversource requested \$15M for base O&M vegetation management activities in 2019, with annual escalation of 2-3% through 2023. Eversource also requested \$5M for Enhanced Tree

³ For example, Staff Testimony stated that the "Company has the burden of justifying the increased expenditure that provides little to no measurable benefits, even if the Company cites a standardization requirement." See Direct Testimony of Kurt Demmer, Docket DE 19-057, December 20, 2019. https://www.puc.nh.gov/regulatory/Docketbk/2019/19-057/TESTIMONY/19-057_2019-12-23_STAFF_TESTIMONY_DEMMER.PDF

Trimming (ETT), \$10M for Enhanced Hazard Tree Removal (ETR), and \$2M for Right-of-Way (ROW) clearing. Staff concluded there was “little to no evidence of overall SAIFI or SAIDI performance as the ETT activity progressed,” noting high costs of ETT compared to scheduled maintenance trimming. Staff recommended no funding for ETT, limited (\$2.5M) funding for ETR, and the full \$2M for ROW clearing.

As part of the settlement of the proceeding, Eversource agreed to engage an expert distribution engineering firm to conduct an assessment of Eversource distribution system infrastructure “to provide recommendations related to the Company’s short and long-term system needs consistent with the requirements of least-cost integrated resource planning.” The assessment was stipulated to include a review of the cost effectiveness of using or conducting:

- Steel poles in right-of-way
- Class 2 poles as a standard pole
- Fiberglass cross arms
- Relocated ROW facilities
- Spacer cable and tree wire
- Reconductoring of under-sized wire
- Enhanced Tree Trimming and Hazard Tree Removal activities

Eversource engaged TRC to conduct the distribution system assessment and related scope as outlined in Section 2.1 herein.

2.1.1 Prior Reliability-Focused Investments and Historical Performance

Eversource established a Reliability Enhancement Plan (REP) in its 2006 rate case, funding capital and O&M spending to improve system reliability. The plan has been extended numerous times since its launch in 2007, including a bridge to the most recent rate case described in the above section, DE 19-057.⁴ In its latest Report to the New Hampshire Public Utilities Commission on the REP program, the Company noted that:

“Since the REP was implemented, the trend from 2006 onward has been improved reliability on a weather normalized basis. Eversource’s customers continue to see benefits from the REP activities. REP programs are preventing problems from occurring (improving SAIFI) and reducing outage times (improving SAIDI) and reducing the number of customers impacted by outages which do occur. The REP activities have proven to be a critical component to improving reliability and have been important in concert with Eversource’s continued efforts to maintain and improve the system in the normal course of business.”

⁴ Eversource, Proposal to Extend Reliability Enhancement Program, De 17-196, November 2018. https://www.puc.nh.gov/Regulatory/Docketbk/2018/18-177/INITIAL%20FILING%20-%20PETITION/18-177_2018-11-16_EVERSOURCE_PETITION_CONTINUATION_REP.PDF

For 2018, the REP program expenditures totaled \$10.4M for O&M activities and \$5.2M for capital expenditures.⁵ In 2019, O&M increased to \$25.3M, and capital expenditures decreased to \$3.5M,⁶ and included the following activities:

- Reject pole replacement
- Direct buried cable replacement
- Regular and enhanced vegetation management
- National Electrical Safety Code inspections
- Switch and recloser maintenance
- Partial funding of the troubleshooter organization.

As of the 2019 REP report, Eversource reported a decrease in SAIDI – the number of average minutes customers were without power – due to the investments made through the REP program. Over the period of 1989 to 2005, annual SAIDI exhibited a consistent increase in SAIDI minutes, or reduced reliability. Since REP began in 2007, Eversource’s SAIDI performance shows a multi-year trend of improved reliability performance or declining SAIDI minutes.

Figure 2-1. Comparison of Pre- and Post-REP SAIDI performance

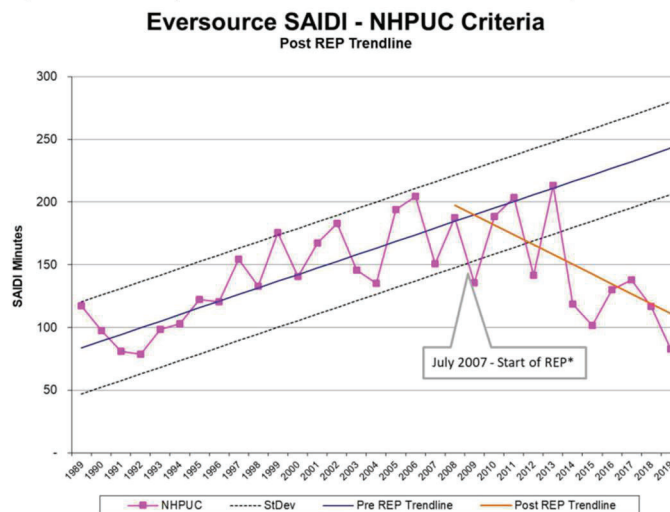

Source: Eversource Reliability Enhancement Program 2019 Report to the NHPUC

⁵ Eversource. Reliability Enhancement Program 2018 Report to the New Hampshire Public Utilities Commission. April 2019. https://www.puc.nh.gov/Regulatory/Docketbk/2018/18-177/LETTERS-MEMOS-TARIFFS/18-177_2019-05-28_EVERSOURCE_REV_2018_REP_RPT.PDF

⁶ Eversource. Reliability Enhancement Program 2019 Report to the New Hampshire Public Utilities Commission. May 2020. https://www.puc.nh.gov/Regulatory/Docketbk/2018/18-177/LETTERS-MEMOS-TARIFFS/18-177_2020-05-01_EVERSOURCE_2019_REP_RPT.PDF

Notably, Eversource also tracks SAIDI performance including Major Storms,⁷ which are removed from the weather-normalized NHPUC Criteria SAIDI results. The comparison of performance with and without Major Storms reveals the impact of these storms since data began in 2000. While some years had few or no Major Storm-related increases in SAIDI minutes, Major Storms in 2008, 2010, 2011, 2012, 2014, and 2017 significantly impacted customer outage durations.

Figure 2-2. Eversource SAIDI Performance Including Major Storms

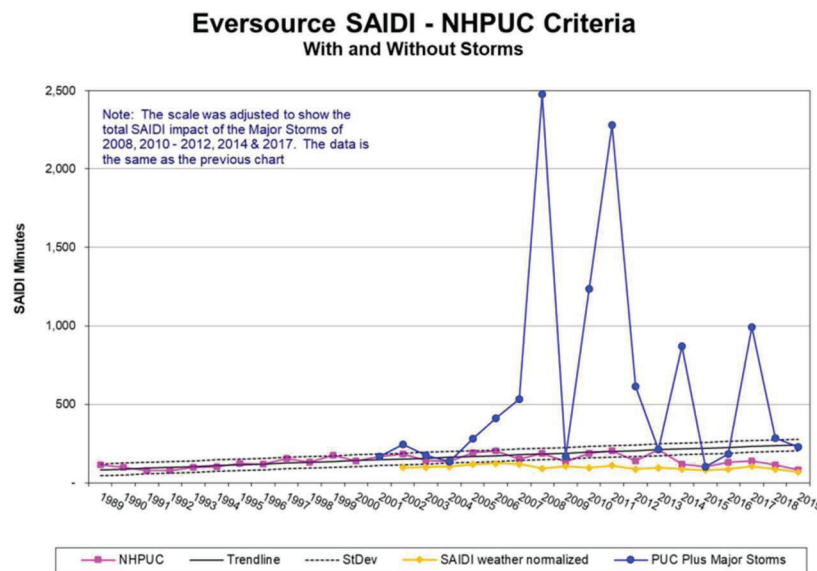

Source: Eversource Reliability Enhancement Program 2019 Report to the NHPUC

The REP focused on asset replacement and vegetation management to improve reliability (i.e., SAIDI, SAIFI metrics). By comparison, the GTEP investments were targeted to refurbish infrastructure to create a more durable and resilient distribution system for major weather events⁸. As shown in *Figure 2-2*, the major weather events have contributed to several spikes in customer outage duration in numerous years since 2000. Five significant weather events since 2008 caused outages impacting over 200,000 customers, or more than 40 percent of the customer base.

The analysis in TRC’s System Assessment accordingly encompasses material, equipment and activities that were included within the REP and (proposed) GTEP programs.

⁷ A Major Storm is defined as an event that results in either: a) 10% or more of Eversource’s retail customers being without power in conjunction with more than 200 reported troubles; or b) more than 300 reported troubles during the event

⁸ Public Service Company of New Hampshire, Direct Testimony of Joseph A. Purington and Lee G. Lajoie - Grid Transformation and Enablement Program: Acceleration of Targeted Infrastructure Upgrades, Docket DE 19-057, 5/28/2019. https://www.puc.nh.gov/regulatory/Docketbk/2019/19-057/INITIAL%20FILING%20-%20PETITION/19-057_2019-05-28_EVERSOURCE_DTESTIMONY_PURINGTON_LAJOIE.PDF

2.2 Objectives of the Distribution System Assessment

TRC's scope of work for this assessment of the Eversource distribution system and plans included the following requirements:

- 1) Assess and evaluate the performance of the existing system at the five and ten-year planning levels, including assessment of the electric system's ability to serve projected load requirements.
- 2) Review industry best practices and challenges experience by peer utilities and stakeholders in developing and evaluating distribution system investment plans for reliability and resiliency.
- 3) Recommend improvements to focus on a broad view of the distribution system to achieve the objective of reliable, resilient, and cost-effective electric service over the ten-year planning horizon, and beyond, with a focus on:
 - a) Asset age and health
 - b) Reliability and resiliency
 - c) Ability to meet future load growth needs through the use of non-wires alternatives, including targeted energy efficiency, electric vehicles, etc.
- 4) Perform a cost-effectiveness analysis of the Company's use of certain materials for distribution line construction, substation, and vegetation management activities, including:
 - a) The use of steel poles for construction in distribution rights-of-way
 - b) The use of Class 2 poles as a standard pole
 - c) The use of fiberglass cross arms
 - d) The potential relocation right-of-way facilities to roadside
 - e) The use of spacer cable versus open wire
 - f) The proactive reconductoring of under-sized
 - g) Enhanced Tree Trimming and Hazard Tree Removal activities.
 - h) Substation transformers and breakers

2.3 System Assessment Methodology

This section details the methodology TRC employed for the Distribution System Assessment.

Introduction

TRC conducted its assessment of Eversource's distribution system in accordance with the Settlement Agreement filed in DE 19-057, dated October 9, 2020. This study provides a condition assessment of the Company's distribution infrastructure, including substations and overhead infrastructure, along with recommendations related to Eversource's short and long-term system needs consistent with the requirements of least-cost integrated resource planning. As part of the condition assessment, TRC reviewed the cost-effectiveness and benefits of utilizing the materials listed below for construction and specific vegetation management activities:

- The use of steel poles for construction in off-road distribution rights-of-way
- The use of Class 2 poles as a standard pole for roadside construction
- The use of fiberglass cross arms
- Distribution planning and potential relocation right-of-way facilities to roadside
- The use of spacer cable versus open wire
- The proactive reconductoring of under-sized wire
- Enhanced Tree Trimming and Hazard Tree Removal activities.

Planning System Assessment

TRC assessed and evaluated the performance of the existing system at the five and ten-year planning levels. The existing system analysis included an assessment of the electric system's ability to serve projected load requirements. Assessing system capacity was area based and looked at the system needs for impacted substations at a time where there is a projected capacity concern. TRC reviewed individual capital projects to evaluate their effectiveness in providing for future growth and making the system more resilient based on cost effectiveness and good engineering practices. In addition, TRC focused on a broad view of the distribution system to achieve the objective of more reliable, resilient, and cost-effective electric service over the ten-year planning horizon, and beyond. This included the following:

- Asset age, health, and condition
- Ability to meet future load growth needs using traditional wires and non-wires alternatives, including targeted energy efficiency
- Reliability and resiliency
- Overall capability of distribution circuits for carrying the load, physical integrity, and ability to recover from outages to minimize the impact on service reliability

Eversource Current Practices

TRC performed a preliminary review of the data and guidelines set forth by Eversource as described in the Direct Testimony of Joseph A. Purington and Lee G Lajoie on May 28, 2019 (current/proposed maintenance programs), and discussions held with subject matter experts to gather contextual information regarding current engineering practices. These discussions included:

- Specific operating problem areas
- Engineering and operating challenges and/or concerns
- Capital project execution including planned or ongoing construction
- Areas of focus for the field assessments per interviews with Eversource's staff

Physical/Visual Inspection of Assets

TRC performed visual inspection of representative portions of the Company's distribution system, both roadside and Right of Way (ROW). Representative portions were determined from

the review of circuit performance data, mapping information, and local utility knowledge. ROW inspections were conducted by helicopter patrol and roadside inspections by motor vehicle to document data and incorporate the results into a formal report.

- **Vegetation:** TRC created a map that shows all line and pole data with aerial imagery superimposed. TRC flagged areas that are suspect to trees that are approximately 13ft from center of the pole.
- **Roadside:** TRC selected and visually inspected several worst performing feeders to view vegetation and condition of the lines. This was done via vehicle and walking in select areas.
- **ROW:** TRC selected and visually inspected a sampling of circuits to see vegetation around the lines, condition, and access issues.
- **Substation:** TRC selected and visually inspected several recently completed improvement projects and planned projects for substation improvement.

Review of Industry and Other Utility Practices

TRC researched regarding best practices and the challenges utilities face evaluating distribution system investments for reliability, resiliency, and hardening. The research assessed varying perspectives, including other utilities, regulators, and industry experts. The data collection activities included:

- Literature review of industry documentation and research regarding best practices for resiliency and system hardening.
- In-depth interviews with three experts from industry organizations and peer utilities, conducted via virtual meetings.

The literature review and interviews collected around several key themes:

- Planning strategies around equipment standards and practices identified
- Utilities demonstration of capital expenditures for distribution system investments
 - Use of benefit-cost analysis and calculation methods
- Future issues impacting distribution system investments: resilience, electrification, and smart distribution systems
 - Concerns around overbuilding systems
 - Deferral and non-wires alternatives
- Regulatory processes and stakeholder views
 - Venues under which utilities propose resiliency investments
 - Coordination with broader distribution system planning activities

TRC analyzed findings from these data collection activities and summarized trends and findings.
Cost-Effectiveness Analysis

TRC performed an analysis relating to the cost-effective use of materials for distribution line construction, substation, and vegetation management. These analyses include:

- Total lifecycle costs of the current or proposed standards or practices compared to an alternative or previous practice.
- Present worth analysis of the practices, where applicable.
- Avoided cost savings by using the new materials.

Methods applied are dependent on the applicability for each new standard or practice. The total lifecycle analysis compared the current or proposed standards or practices total ownership cost, to an alternative or previous practice for the anticipated in-service life for each of the components or practices. Equipment in-service useful life was acquired from industry data or Eversource historical information. Built into the lifecycle cost model were the following assumptions:

- Labor, material, and overhead costs to install the equipment
- Escalation rates of labor and materials provided by Eversource
- Maintenance costs (escalated) over the life of the equipment. Specific rates are included in each cost analysis assumptions.
- Other assumptions applicable to the equipment or practice.

The present worth analysis includes the assumptions listed above for the lifecycle analyses with carrying charge and discount rate provided by the Company. Present worth analysis is not applicable to all scenarios.

Avoided cost analysis calculates the incremental cost not incurred by using a current or proposed standard. This method is used in the larger class wood poles scenario.

2.4 Organization of the Distribution System Assessment

The remaining sections detail the results of TRC's research and analysis. They are organized as follows:

- Chapter 3 reviews the industry findings from the literature review and expert interviews.
- Chapter 4 provides an assessment of the age and condition of various distribution system elements, with focus on the impact of each equipment type and work practice used to support the system. Also included is an overall assessment of the system, to provide a broader picture of areas where additional investment may be needed.
- Chapter 4.0 details the assessment results for distribution line, substation, and vegetation management materials and practices. In each section TRC reviews current practices, typical usage and installation parameters, industry findings, details of the business case and cost analysis, and recommendations.
- Chapter 6 provides a summary of findings and recommendations.

3. Review of Industry Practices for Reliability and Resiliency Investment Planning

Utility activities for resiliency planning and investment have accelerated across the country over the last two decades, spurred by several factors, including 1) increases in extreme weather events, 2) customer desire for shorter and less frequent power interruptions, and 3) new or improved technologies. Responding to these factors, utilities are upgrading and updating their systems to enable harder, smarter grids that can better withstand, react to, and recover from outages.

While many resiliency investments are similar or even identical to distribution system and reliability-related investments utilities have made for decades, they are designed to prevent a different category of risk than historical distribution system investments. As a result, utility and regulatory methods for valuing and evaluating these types of investments are less well developed than those made for traditional reliability outcomes.

This chapter reviews practices among utilities and regulators around the country to plan for and assess investments to improve resiliency through system hardening efforts. As part of this research, TRC conducted a literature review of published studies and utility documentation related to resiliency planning and interviewed experts on current trends and best practices. The sections below detail findings related to:

- Growing interest and activity around resiliency and grid hardening
- Frameworks for utility resiliency planning
- Evaluating cost-effectiveness for resiliency and hardening investments
- Regulatory and stakeholder input
- Implications for Eversource

Key findings from the literature review and expert interviews include:

- 1) Increased resiliency and hardening investment and planning activity across the majority of states is driven by an increase in severe weather events that can significantly impact outage durations.
- 2) Resiliency planning frameworks stress assessment of local climate risks to identify tailored solutions for each utility.
- 3) Evaluating cost-effectiveness of resiliency investments remains a critical challenge for utilities and regulators, as the benefits are difficult to monetize.
- 4) Shifts in the traditional utility business model are impacting investment decisions. The move away from a cost-plus ratemaking approach and moving to a performance-based structure (e.g., New York and Massachusetts) has allowed regulators to incorporate metrics around grid hardening and provides greater flexibility to utilities in their system investment.

- 5) Cost recovery remains central to the ongoing industry debate. This research identifies various approaches currently being advanced, presented later in this chapter. These approaches demonstrate the range in considerations and fragmented nature of the responses across the country.

3.1 Resiliency, Grid Hardening, and State interest in Integrated Distribution and Resilience Planning Initiatives

Over the last two decades, investor-owned utility spending on distribution system investments has grown over 2.5 times, from \$14 billion in 1999 to nearly \$40 billion in 2019. An estimated two-thirds of that capital spend in 2019 is driven by emergency repairs, aging infrastructure replacement, reliability improvements, or resiliency. The 2019 spend on aging infrastructure replacement, reliability and resiliency alone is greater than the total distribution system investment from the 20 years prior. As the scale of these investments has grown, states are increasingly looking to integrated planning initiatives for distribution and resiliency. The Department of Energy counted 29 states and territories where regulatory commissions have begun such an effort as of 2019.⁹

Resiliency includes the ability to harden the power system against, and quickly recover from, high-impact, low-frequency events.¹⁰ Such events can threaten lives, disable communities, and devastate generation, transmission, and distribution systems. Included are severe weather or natural events such as:

- Hurricanes and consequent flooding,
- Severe wind events
- Earthquakes and consequent tsunamis
- Wildfires
- Ice storms

Reliability is the adequacy of the system to provide customers a continuous supply of electricity at the proper voltage and frequency, virtually all of the time. The system needs to withstand sudden, unexpected disturbances such as short circuits and unexpected loss of system elements due to natural or man-made causes. There are three commonly used standard industry performance measures for reliability:

- System Average Interruption Frequency Index (SAIFI)
- Customer Average Interruption Duration Index (CAIDI)
- System Average Interruption Duration Index (SAIDI)

⁹ U.S. Department of Energy, Resiliency Decision Framework – Presentation to NARUC 2019 Annual Meeting, November 20, 2019. <https://pubs.naruc.org/pub/6A146D0E-B6A2-89F8-1469-484C2B6E8FFE>

¹⁰ ELECTRIC POWER SYSTEM RESILIENCY: CHALLENGES AND OPPORTUNITIES, February 2016

Both resiliency and reliability are affected by various factors such as the age and condition of assets, vegetation, and severe events.

In many cases it is difficult to delineate investments for reliability, aging infrastructure replacement, emergency repairs, and resiliency. However, the literature makes clear that, unlike general reliability, resiliency is specifically targeted at major events, typically those causing outages of 24 hours or longer. These events are unexpected, infrequent, and their impacts are widespread.¹¹ Typical measures of reliability—system average interruption frequency and duration indexes (SAIFI and SAIDI)—are designed to factor out these major events given their unpredictability. As shown in Figure 3-1 below, when major events are included, the frequency index only increases by 17%, but the duration index with major events factored in is 74% longer than without major events.

Figure 3-1. EIA-reported SAIDI and SAIFI performance for 137 Investor-Owned Utilities in 2015

IEEE Standard 1366	Investor-Owned Utility 2015 Reliability Reporting	% Difference with Major Events
SAIFI without major events	1.2	
SAIFI with major events	1.4	+17%
SAIDI without major events	136	
SAIDI with major events	237	+74%

SOURCE: LAWRENCE BERKELEY NATIONAL LABORATORY

Discussions with industry experts suggest that the increased interest in resiliency in many states is most often prompted after a widespread or extended outage, such as a major weather event. However, after such an external event, “there’s a lot of activity, a lot of grandstanding,” but only in some cases, do states and energy providers follow through with investments in system hardening. An expert noted that Texas faced a significant winter storm in 2011 that pointed to the need to winterize assets, but a similar significant winter storm in 2021 revealed little had been done to address system deficiencies that were identified 10 years earlier.

Florida and New York, by contrast, made significant investments in hardening their systems after weather events caused major interruptions. Following hurricanes in 2004-2005, Florida regulators in 2006 instituted requirements for storm-hardening plans on a three-year cycle, along with a set of 10 initiatives for inspection, hardening and local collaboration to reduce impacts of future storms. Similarly, following the 2012 impacts of Superstorm Sandy in New York, regulators created a resiliency collaborative, and Con Edison developed a resilience enhancement plan with estimated incremental costs. Once approved, this began a multi-year system-hardening initiative that included asset relocation, strengthening, and improved flexibility

¹¹ Lawrence Berkeley National Laboratory, Reliability Metrics and Reliability Value-Based Planning, March 2019. https://eta-publications.lbl.gov/sites/default/files/6_eto_reliability_metrics_and_rvbp.pdf

using advanced controls to reduce the impacts of potential flooding or high winds.¹² While the outcomes are similar, some states, such as Florida, have not specifically described these investments under a “resiliency” frame, while other states are more explicit about outlining planning and investments as “resiliency.”

The Electric Power Research Institute (EPRI) characterizes resiliency within three categories:¹³

- **Damage Prevention:** the application of engineering designs and advanced technologies that harden the power system to limit damage.
- **System Recovery:** the use of tools and techniques to restore service as soon as practicable.
- **Survivability:** the use of innovative technologies to aid consumers, communities, and institutions in continuing some level of normal function without complete access to their normal power sources.

Damage prevention, often referred to as hardening, helps reduce the frequency of these events; system recovery aims to address the duration; survivability acknowledges that, as one expert interview noted, there is no perfect level of system reliability in practice. Given the focus of this assessment, this chapter primarily focuses on findings related to distribution grid hardening activities. These types of activities include vegetation management and enhancing or reinforcing the physical strength and security of distribution facilities against storms or attacks. Though not a focus of this assessment, one area of significant recent research, due to increasing severity of storms and wildfires, is the undergrounding of distribution and transmission circuits.¹⁴

3.2 Resiliency and Hardening Planning Frameworks

The Department of Energy notes that, despite the increased interest across much of the country, resiliency “planning methods and tools are largely immature or non-existent” today.¹⁵ Several of the studies reviewed pointed to the significant uncertainty of climate and resiliency needs leading to difficulty determining the appropriate timing and level of investment. Lawrence Berkeley National Lab (LBNL) points out there is “no actuarial basis to establish a likelihood of occurrence” of significant weather or outage events.¹⁶ A white paper from consultancy ICF, which works with utilities on integrated grid planning and climate analysis, notes that “lack of insight into the degree of infrastructure exposure” and “the complexity around how to measure

¹² Lawrence Berkeley National Lab, Case Studies of the Economic Impacts of Power Interruptions and Damage to Electricity System Infrastructure from Extreme Events, November 2020. https://eta-publications.lbl.gov/sites/default/files/impacts_case_studies_final_30nov2020.pdf

¹³ EPRI, Electric Power System Resiliency: Challenges and Opportunities, February 2016. <https://www.epri.com/research/products/000000003002007376>

¹⁴ Larsen, Severe Weather, Power Outages, and A Decision to Improve Electric Utility Reliability, March 2016. <http://purl.stanford.edu/sc466vy9575>

¹⁵ U.S. Department of Energy.

¹⁶ LBNL (Reliability Metrics and Reliability Value-Based Planning)

vulnerabilities, hazards, and stressors” make planning for resiliency investments challenging.¹⁷ This uncertainty also makes it difficult to value those investments’ costs and benefits. This topic is further addressed in Section 3.4.

Industry experts noted utilities’ current reliance on the Interruption Cost Estimate (ICE) Calculator developed by LBNL and Nexant.¹⁸ Funded by the Department of Energy, this tool can be used to help estimate direct societal costs of power interruptions to assess investments in reliability by understanding the avoided costs for customers from outages. However, the tool’s accuracy and usefulness degrade for outage events longer than 24 hours, as the inputs used for modeling were not designed around these types of major events. For example, the costs of a shorter, typical outage are generally contained within a utilities’ service area. But a longer, multi-day outage has the potential to have national impacts as supply chains and other interstate systems are halted until power is restored. Because the costs of long-duration outages are less well understood at present, they are often not factored into utility planning decisions as completely as short-duration outages.¹⁹

Nonetheless, several utilities have taken more structured approaches to resiliency planning. Examples from Con Edison and Florida Power and Light are detailed below. In many cases these planning exercises are compelled by state regulators or legislatures, prompted by one or multiple significant outage events. The Department of Energy proposes that utilities need to begin transitioning from reactive resiliency investments to those that are proactive, anticipating future impacts as new hazards emerge.²⁰

Industry Example: Con Edison

Con Edison recently published a Climate Change Vulnerability Study²¹ that addresses resiliency planning through better understanding of the risks to operations and assets from climate change. First, the utility characterizes each of the major threats to the utility’s energy system, including heat and temperature, precipitation, flooding and sea-level rise, and extreme and multi-hazard events. Next, based on a better understanding of climate science and projections for extreme weather, Con Edison can assess and prioritize the risks these threats pose to operations, planning and assets, evaluate costs and benefits of mitigations, and then prioritize paths to improve resiliency. Stemming from the Vulnerability Study, Con Edison will complete a

¹⁷ ICF, Resilient Power: How Utilities Can Identify and Effectively Prepare for Increasing Climate Risks, March 2021. <https://www.icf.com/insights/energy/resilient-power-utilities-prepare-climate-risks#>

¹⁸ See: <https://www.icecalculator.com/home>

¹⁹ Lawrence Berkeley National Laboratory, A Hybrid Approach to Estimating the Economic Value of Enhanced Power Resilience, February 2021. https://eta-publications.lbl.gov/sites/default/files/hybrid_paper_final_22feb2021.pdf

²⁰ U.S. Department of Energy – Office of Electricity, North American Energy Resilience Model, July 2019. https://www.energy.gov/sites/default/files/2019/07/f65/NAERM_Report_public_version_072219_508.pdf

²¹ ConEdison, Climate Change Vulnerability Study, December 2019. <https://www.coned.com/-/media/files/coned/documents/our-energy-future/our-energy-projects/climate-change-resiliency-plan/climate-change-vulnerability-study.pdf?la=en>

Climate Change Implementation Plan with a timeline for risk mitigation measures, scope, and costs for 5-, 10-, and 20-year plans.

Regarding proactivity, Con Edison notes that, “the key to designing resilient infrastructure is to update design standards, specifications, and ratings to account for likely changes in climate over the life cycle of the infrastructure.” Standards should not be based solely on historical impacts, but on expected needs over the asset’s expected useful life. In other words, while historical asset performance may be one indicator of investment needs, it should not be the only factor considered. Con Edison also highlights the need to remain flexible as future conditions change. In a review of studies on grid hardening, the Edison Electric Institute further noted that while storm response creates a natural opportunity for replacing assets with harder equipment, hardening activities or replacements should also be included with regular maintenance.²²

Industry Example: Florida Power and Light

Florida Power and Light (FPL) has 15 years of planning for storm hardening, a requirement that began in 2006 following significant hurricanes in previous years. The state legislature in 2019 extended requirements for utilities to file Storm Protection Plans every three years, with a 10-year planning horizon. The 2020-2029 plan²³ includes elements divided among distribution, transmission, and substation, with a focus on pole/structure inspection, circuit hardening and undergrounding, and vegetation management.

For the distribution feeder hardening initiative, FPL upgrades existing feeders and certain critical distribution poles—and designs new lines—to meet “extreme wind loading” criteria established by the National Electric Safety Code. The utility is targeting this hardening or undergrounding of all distribution feeders by 2024. FPL conducted forensic analyses of prior storm events to find that wind was the primary cause of pole breakage, and that performance of assets built to the extreme wind loading standard was sufficient. Before conducting work on a specific circuit, FPL conducts a field survey of the facilities in place to determine what is needed to meet the required wind ratings for that region. The utility also relies on a toolkit of designs to harden circuits, including storm guying, equipment relocation, adding intermediate poles, upgrading pole classes, and undergrounding facilities. FPL also prioritizes these activities based on spreading projects throughout the service territory, historical performance, areas with restoration difficulties, and coordination with ongoing or municipal projects. While FPL estimates the cost of the program (roughly \$500-650 million/year between 2017 and 2025), its estimation of benefits is mostly qualitative, primarily citing the improved reliability of feeders that have been hardened to meet new standards (benefits to customers), in comparison to feeders that have not yet been hardened. FPL also notes the reduction in additional restoration costs. FPL conducted analyses to estimate these restoration cost savings based on the magnitude of damage from previous observed hurricanes.

²² Edison Electric Institute, Before and After the Storm, March 2014.
<https://www.energy.gov/sites/prod/files/2015/03/f20/Edison%20Electric%20Institue%20Comments%20and%20Resources-%20QER%20-%20Enhancing%20Infrastructure%20Resiliency%20FINAL.pdf>

²³ Florida Power and Light’s 2020-2029 Storm Protection Plan, Exhibit MJ-1.

The above examples demonstrate an important point from the literature: utilities must develop and tailor plans that are specific to the unique risks to their region and the sensitivities of their own assets.²⁴ Mitigation strategies designed for areas prone to wildfires in the West may not be appropriate to address hurricanes in the Southeast, ice storms in the Northeast, or wind in the Midwest. The utilities above also generally follow the Resilience Decision Framework proposed by the Department of Energy, which is shown Figure 3-2 below.

Figure 3-2. Resilience Decision Framework Development Process

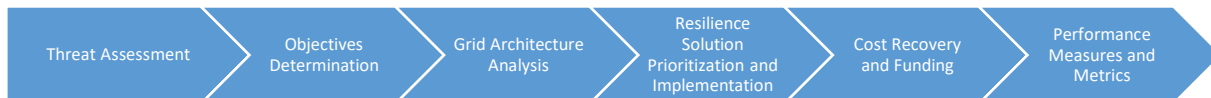

Source: U.S. Department of Energy, Office of Electricity

One expert noted in an interview that ideally, hardening initiatives are not just planned around climatic threats, but future distribution system planning as well. For example, severe weather risk may point to a potential need for stronger distribution poles in the near term. But stronger poles may be needed in the medium-to-long term due to expected load growth necessitating reconductoring, or anticipated increases in attachments to the pole as more smart equipment is added. The Department of Energy’s Decision Framework also advocates for this “whole grid view”²⁵ to enable greater understanding of implications and coordination. This more holistic view can also help improve analysis of cost-benefit, as resiliency measures are aligned with greater overall system needs and future trends for beneficial electrification and growth in electric vehicles.

3.3 Estimating Cost Effectiveness of Resilience

Perhaps the greatest barrier to making needed improvements for resiliency is the difficulty in valuing the benefits of these plans and investments. Without accurate ways to account for these benefits, utilities, regulators, and their stakeholders have difficulty determining which activities to pursue, how much of a given activity is the right amount, or how resilient a new asset should be. These types of investments are not able to be valued as easily as reliability improvements that lead to reductions in SAIFI and SAIDI—or demand response, energy efficiency, or generation investments. While the industry does not have a standard protocol for valuing the benefits and costs of resiliency investment, research is ongoing in this area with a recognition that there is a risk to simply wait until there is a proven process before making investment decisions.

Expert interviews indicate there are three primary ways utilities have described the value proposition of investments in resiliency, each problematic in its own way: First, some utilities simply state that they can’t quantify dollar values and point to qualitative benefits instead. Second, utilities may use the ICE calculator (described above) and extrapolate values out

²⁴ ICF.

²⁵ U.S. Department of Energy.

beyond 24 hours, though the tool is not designed for this use. Third, utilities may attempt to quantify cost-benefit, instead of cost-effectiveness, leaving the monetary value of those benefits undetermined.

Further complicating the cost-effectiveness picture is the infrequent but extreme nature of resiliency events that make their impacts highly uncertain. In turn, it is difficult to accurately assign costs to these low-probability, variable events.²⁶ Despite these challenges, regulators still want to know “what works best and how to direct ratepayer money to the most effective solutions.”²⁷

From the examples in Florida and New York noted above, FPL has been able to justify its investments and quantify avoided costs due to years of similar storms and over a decade pursuing resiliency investments and activities.²⁸

3.4 Regulatory Review of Hardening Initiatives

Increased spending on distribution system investments for asset replacement, hardening, and resiliency has prompted increased interest and review by regulators and stakeholders working to ensure utility investments are made in customers’ best interests. Whether reacting to previous extreme events or reviewing proactive proposals, regulators face competing priorities in evaluating such investments. Discussions with experts (including former state regulators) point to the need to balance affordable rates for customers while also ensuring high levels of reliability amidst increasingly severe weather events.

Further confounding regulatory processes is the challenge of understanding the cost-effectiveness of resiliency investments. This makes it difficult for utilities to prove their proposals are prudent, despite a perceived need prompted by increasing large-scale outage events. LBNL found in interviews with regulatory staff that generally there was little distinction between reliability and resilience among economic regulators in how they evaluate proposed investments. However, as noted in the previous sections, while related, these two concepts have differences in the types of events they seek to address, and the metrics to measure their performance are increasingly different (in fact, research into determining appropriate resiliency metrics is still ongoing).²⁹

Research indicates that hardening activities are often proposed and considered within general rate cases, as these types of investments align with the proceedings where “classic asset

²⁶ EPRI.

²⁷ National Association of Regulatory Utility Commissioners, State Commission Staff “Surge” call: Evaluating Reliability Investments.
<https://www.naruc.org/default/assets/File/Surge%20grid%20hardening%20summary%20051418-final.pdf>

²⁸ ICF.

²⁹ Lawrence Berkeley National Laboratory, Evaluating Proposed Investments in Power System Reliability and Resilience: Preliminary Results from Interviews with Public Utility Commission Staff, January 2017.
<https://eta-publications.lbl.gov/sites/default/files/lbnl-1006971.pdf>

management” activities are typically reviewed. A 2018 discussion among state regulatory staff pointed out that including these investments in general rate cases can make it difficult for staff to separate those investments and weigh them against the benefits of reduced interruptions.³⁰ Increasingly, resiliency activities are proposed and coordinated in separate proceedings, where they can be reviewed in conjunction with other grid modernization activities and long-term planning.

Utilities and regulators are also beginning to look toward new methods for cost-recovery of resiliency and hardening investments. The Edison Electric Institute points to examples in eight states and territories³¹, including:

- Financial penalties in Connecticut, Massachusetts, and Illinois for non-compliance with increased performance standards and metrics from grid modernization plans, tree trimming and hardening measures.
- Financing via public bonds to support undergrounding in Washington, D.C.
- Performance-based formula rates for investments in transmission and distribution systems in Illinois.
- Performance and outcome-based incentives in New York to achieve objectives of reliability and resiliency.
- New rate adjustment mechanisms in Indiana, Pennsylvania, and Texas to allow for cost-recovery of distribution investments between rate cases.

The example of undergrounding funded via public-private partnership in Washington, D.C., highlights another issue raised by experts. As previously noted, resiliency investments provide benefits that may be regional or national, as long-duration outage events can indirectly impact customers outside of a given utility’s service area. As a result, non-utility funding, either from local, state, or federal sources, can be appropriate, given the wider scope of these indirect impacts and benefits.

Finally, research indicates that equity can be an increasing issue of importance in planning and review of resiliency investments. This can come into consideration for prioritization of projects, where utilities may overlay historical outage performance with areas of disadvantaged or low-income communities to identify if that performance disproportionately impacted “socially vulnerable” customers. The utility can then prioritize projects in those areas to ensure benefits of resiliency and hardening accrue to those most impacted. Existing tools for estimating outage impacts and costs (i.e., the ICE calculator) may not sufficiently factor these equity-focused issues into their inputs and analyses.

³⁰ NARUC.

³¹ Edison Electric Institute.

3.5 Implications for Eversource Hardening Activities

The Company's practices and plans to increase standards and activities for system hardening align with trends observed in utilities across the country responding to increases in severe weather and long-duration outage events, improvements in technologies, and higher customer reliability standards. Typically, these changes are prompted by one or repeated widespread, long-duration outage events, and often utility and regulatory activity is spurred by legislative action after these events.

The Company is taking a more proactive, rather than reactive, approach updating standards and practices for distribution system resiliency without significant prompting. TRC recommends that the utility consolidate its current resiliency/hardening efforts into an overarching program following the decision framework outlined by the Department of Energy in Figure 3-2 in assessing threats posed by climate or other external factors, identifying resiliency objectives, and then tailoring and prioritizing solutions based on the data and goals defined. Con Edison's Climate Change Vulnerability Study provides a template for this future-looking threat assessment. Florida Power and Light's Storm Protection Plan also exemplifies targeted solutions tailored to individual project conditions but built to meet a specific and defined standard against wind hazards.

As detailed in Section 3.3, identifying the values of avoided costs resulting from resiliency investments is particularly difficult given the rare nature of severe events, and indirect, widespread impacts that these events have. As a result, traditional measures of cost-effectiveness are likely insufficient at truly capturing the value of the increased standards or enhanced hardening practices that Eversource has proposed. To the extent the Company can quantify or qualify the benefits from increased hardening activities and investments, it may provide regulators and stakeholders more context around these investments, in lieu of difficulties calculating traditional cost-effectiveness.

Further, identifying areas of crossover or co-benefits between distribution hardening activities and other grid modernization initiatives and investments may help ensure that choices being made today for reliability or resiliency also support future plans or customer needs. For example, decisions to strengthen pole standards today for storm hardening may also align with anticipated growth in needs to support additional utility or non-utility attachments over the life of that pole. Updates to substations might consider if significant new or critical loads may be expected to be served by that asset, and the implications of its failure with more customers served in the future.

Finally, it is standard practice to consider the grid hardening investments evaluated within this assessment as part of a general rate case. Eversource should continue to track the performance of these assets and circuits in comparison to those that have not been hardened so that the utility, regulators, and stakeholders can understand the reliability and resiliency benefits that these activities support.

4. Distribution System Age and Condition Assessment

This section provides an assessment of the age and condition of various distribution system elements, with focus on the impact of each equipment type and work practice used to support the system. Also included is an overall assessment of the system, to provide a broader picture of areas where additional investment may be needed.

The Company's electric distribution system in New Hampshire consists of approximately 12,200 miles of overhead distribution circuits, including approximately 3,000 miles of roadside, three-phase distribution circuits and 600 miles of distribution lines within off-road rights-of-way. Approximately 17% of the distribution system is considered backbone and the remaining 83% consists of overhead laterals stemming off backbone circuits.

The distribution system is dynamic and constantly changing with upgrades, new line extensions, relocations, removals, and maintenance activities. The distribution facilities reviewed ranged in age from equipment that was installed in the early 1900's to equipment that will be installed in 2021. Information pertaining to the age, condition and in-service dates are not always available to assess the remaining servicing capabilities and make specific recommendations for each individual piece of equipment. However, the data available shows that there are significant numbers of distribution equipment still in service, that are beyond their expected life expectancy.

The equipment attributes evaluated were provided from the Company's GIS and other data sources to the extent possible. The in-service records for distribution poles and substation transformers were readily available and the data is analyzed in this report to draw conclusions and provide recommendations as to the funding levels, maintenance intervals and equipment replacement strategy to build and maintain a resilient distribution system. Other equipment, such as primary conductors, do not have specific aging information and are generally addressed as part of the overall Distribution Poles and Equipment Assessment. TRC's experience has been the primary conductor typically stays with the original pole line installation and is replaced when the line is reconductored and the older facilities retired. There is still a strong possibility that older primary conductor remains in service when poles are replaced due to damage or failing the pole inspection program and these older primary lines are to be considered for reconductoring as part of the aged facility assessment.

Transformers, reclosers and other distribution equipment attached to the poles are independent of the pole installation and their in-service dates vary greatly depending on the customer requirements and operational needs. The impact of this equipment age and condition on the overall system should be addressed separately to assess the service capabilities. The exception is the third-party attachments as they affect the pole structural load carrying ability that cause premature pole failure due to overloading. The impact of the third-party attachments is addressed in the Pole Loading Assessment of Existing Eversource Poles.

New Hampshire is ranked second in the United States for forest cover, with an estimated 84% covered in timberland.³² Most of the overhead distribution lines are in forested areas and subject to vegetation management. Tree canopy has matured over the years and in many cases, towers over the existing distribution system. Mature trees, commonly reaching 100 ft. in height, are outside of the rights of way, making power lines vulnerable to trees well outside of the maintained rights of way. Information on the Vegetation Management program is also readily available and a detailed evaluation, impact of changing the existing practices and recommendations, are provided and present a clear direction to the program. The data and evaluations tools available for this specific program offer a defined link between the expenditures and impact to the customers and reliability of the system.

The substation transformer and breaker assessment focus on those specific pieces of equipment. The remainder of the substation equipment (buss work, structures, and protective equipment) are not part of the evaluation. These elements should be evaluated separately as their serving capabilities are independent of the substation transformers and breakers.

The Company develops a 5-year plan for capital expenditures to provide adequate capacity for serving customer load and providing reliable service. Similar to other utilities that TRC has worked with, aging assets, higher customer expectations and resilience of the system have become emerging considerations. The capital budget plan addresses these issues in a timely manner, incorporating financial prudence and sound engineering judgement. There are multiple factors considered by distribution planners that affect different stakeholders, each with varying priorities. These include:

- Public and employee safety
- Circuit reliability data
- Age of assets
- Operations experience
- System hardening needs
- Capital funding availability
- System planning criteria and capacity requirements
- Customer impact
- Regulatory requirements

Selecting the projects for the budget plans takes into account many of these factors in conjunction with discussions between the various disciplines within the Company leadership. Capital plans contain line items for individual projects and programs for annual funding to address ongoing work related to maintenance, replacement of assets and reliability

³² USDA - Forest Inventory and Analysis Fiscal Year 2016 Business Report. Page 71-72. Table B-11. Land and forest area and FIA annualized implementation status by State and region, FY 2016. (Percentages for states derived by dividing third column by second column.) Data for territories: Page 70: Table B-10. Status of FIA special project areas excluded from annualized inventory. Retrieved January 8, 2019

improvements. Examples include pole inspection and replacements, reliability projects under \$100,000 and distribution automation. These programs address both known and emerging issues that engineering, operations, and other stake holders identify.

Distribution Poles and Equipment Assessment

The Company has maintenance responsibility for 276,000 distribution poles and has distribution facilities attached to approximately 455,000 poles that are either jointly or solely owned by the Company.³³ Upon reviewing the pole data provided from the GIS database, two concerns are emergent: the age of the poles and the structural load placed on the poles with attached equipment.

4.1 Pole and Equipment Age Analysis

The overhead distribution system is currently comprised of a large proportion of older, outmoded utility poles originally built to serve smaller electrical loads. Currently, 39% of the distribution poles owned and maintained by PSNH are over 40 years old, with more than 57,500, or nearly one-quarter of poles, exceeding 50 years. This is beyond the estimated useful life of 45 years for a wood distribution pole. Figure 4-1, below, shows the age groupings of the Company’s distribution pole inventory taken from the GIS data.

Figure 4-1. Age of Distribution Poles by Year Grouping

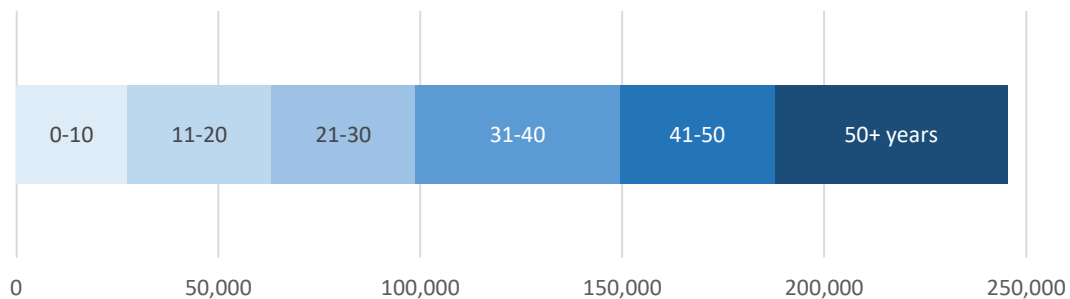

Source: Eversource GIS, 2019

Wood poles can remain in service for longer than 50 years when regularly inspected and treated as necessary. However, as wood poles age beyond their expected useful life, they experience a loss of strength from the natural degradation of the wood due to structural wear and decay from fungus, insects, and animals. One analysis of wood pole decay rates indicates strong evidence that the probability of pole degradation accelerates rapidly in poles over 50 years old.³⁴

Typically, the Eversource equipment (framing, conductors, down guys, etc.) attached to the older poles are of the same vintage as the poles and will also need to be replaced along with the pole. In TRC’s experience, it is a common and good utility practice, to inspect/maintain poles, and replace them prior to failure. The Company conducts a wood pole inspection

³³ Eversource system data

³⁴ Timing of Wood Pole Replacement Based on Lifetime Estimation, Steiner Refsnaes, Lars Rollfseng, Eivind Solvang and Jorn Heggset, July 2006

program to identify and replace failing wood poles, but the pace of replacement of the older poles is not adequate to address all aged wood poles in a timely manner.

Aging poles may also be structurally overloaded and not be able to carry the load of conductors, transformers, reclosers, third-party attachments, etc. in an NESC Heavy Loading Zone. The NESC initially added wind and ice loading criteria in 1940, and the most recent specifications were published in 2017. An analysis of the structural strength of the poles, compared to existing poles that have been analyzed is addressed in the Pole Loading Assessment below. Pole aging and the loss of pole strength are closely linked and need to be addressed together when pole assessments are performed.

4.1.1 Pole Loading Assessment of Existing Poles

TRC conducted an analysis on the ability of the existing poles to withstand the structural wind and ice loads that are experienced in the New Hampshire NESC Heavy Loading Zone³⁵. Specifically, the 2017 NESC requires that all distribution facilities be designed to withstand a 40 MPH wind with ½" of ice on the line at 15° F. Requirements are also in place for the facilities to withstand a 95 MPH wind at 60° F. This analysis focuses on the first design criteria of the Heavy Loading wind and ice requirement.

TRC did not have individual pole loading information for the Company's NH service territory; instead, this analysis relied on a proxy dataset of loading for 41,000 poles from a representative utility that uses similar construction. TRC then applied the results of that analysis to the Company's pole population as an aggregated group, to identify the average pole loading and number of poles that may be overloaded.

The analysis of the representative utility data calculated the strength of poles installed in the field and in the same NESC Heavy Loading Zone. Actual pole loading data was not extensively available for the Company's poles. Poles were analyzed by pole class, with all primary conductor types and a varied number of third-party attachments. TRC used the SPIDAcalc analysis tool to determine the average pole loading and the percentage of poles that are structurally overloaded. The assumptions for the representative utility pole calculations are listed below. Poles in this data set are in the field with known class, attachments, and span lengths.

- Pole loading is the average of all poles with those attributes (primary conductors and third-party attachments).
- % Overload is the percentage of locations where the poles are overloaded.
- Only situations with 6 primary wires (each primary line on a tangent pole is modeled as two wires for calculation purposes) or three phase lines.
- Includes all primary conductor sizes.

³⁵ 2017 National Electric Safety Code

- Heavy–Grade B Loading
- All representative utility field data was collected with a Hastings Hotstick and TruPulse laser.
- Structural analysis was performed using SPIDA Software’s SPIDAcalc application.
- The data used for this analysis spans from 2009 to 2021 and includes a total of 41,314 locations.

For purposes of this report, the poles analyzed were the most common three phase poles in service today utilized by Eversource. These are the 40 and 45-foot poles in classes 1, 2, 3, 4 and 5. The data are presented below in Figure 4-2 as the Percentage of Poles Overloaded by Class and Attachments of the representative utility.

Figure 4-2. Percentage of 40 and 45-foot Poles Overloaded by Class and Attachments (Representative Utility Data)

Pole Size (ft) & Class	Number of attachments							
	0	1	2	3	4	5	6	7
40-1	0.00%	12.00%	0.00%	60.00%				
40-2	3.13%	7.57%	11.76%	26.67%	25.32%	26.09%		
40-3	7.14%	8.79%	19.40%	32.14%	12.50%	100.00%		
40-4	14.45%	25.55%	30.96%	37.56%	46.15%	66.67%	75.00%	
40-5	33.33%	45.77%	48.15%	40.00%	80.00%	50.00%	100.00%	
45-1	0.00%	7.02%	7.50%	25.00%	17.86%	16.00%		
45-2	5.34%	8.59%	15.59%	20.87%	18.85%	29.12%	28.89%	25.00%
45-3	13.33%	25.23%	22.61%	35.38%	52.17%	37.50%	100.00%	
45-4	21.10%	27.25%	38.62%	37.50%	48.42%	33.33%	66.67%	60.00%
45-5	40.00%	56.41%	58.33%	0.00%				

Source: TRC analysis of Representative Utility data

Pole data provided from Eversource are shown in Figure 4-3 below. There are 148,988 40-foot and 30,500 45-foot poles which were recorded in the GIS system without the class designation. Based on TRC’s discussions with Eversource SME’s, these are likely older poles that were installed and not recorded with the same attributes as the GIS captures today. Eversource indicated that prior to the 1980’s, Class 4 was the standard for 40 and 45 ft. poles. It is likely the majority of the 40 and 45 ft poles are Class 4. For analysis purposes, TRC conservatively assumed that these unclassified poles are Class 3. As of 2016, Class 2 poles are the standard and are shown in the chart below. It is noted that the pole data includes all poles that Eversource has facilities attached, not just the poles the Company owns and maintains. The 40-foot and 45-foot poles were chosen because they will typically be used for construction of the three phase facilities.

Figure 4-3. Eversource 40 and 45-foot Poles by Length and Class

Pole Length	Pole Class	# Poles
40 Foot	Unknown	148,988
	1	113
	2	19,847
	3	20,545
	4	459
45 Foot	Unknown	30,533
	1	647
	2	15,317
	3	3,137
	4	9

Source: Eversource GIS

The Company's SMEs estimated that there is an average of two attachments by third-party companies on each pole with many poles having more. Looking at the number of 45-foot Class 3 poles, as an example, and using the 23% of poles overloaded from the Representative Utility data analysis in Figure 4-2, we can conclude that there are potentially 7,700 (15% of 45-foot poles) overloaded and could fail during a heavy loading event. The number of poles subject to failure is shown in Figure 4-4, below. Availability of specific pole size, class, conductor, and third-party attachments data would be needed to provide information to assess each individual pole.

Figure 4-4. Estimated Percent of Eversource Poles Overloaded by Class

Pole Length and Class	# Poles	Avg Pole Loading w/2 Attachments	# Poles Overloaded
40 (Assume Class 3)	148,988	19%	28,904
40, 1	113	0%	0
40, 2	19,847	12%	2,332
40, 3	20,545	19%	3,986
40, 4	459	31%	142
45 (Assume Class 3)	30,533	23%	7,023
45, 1	647	8%	52
45, 2	15,317	16%	2,388
45, 3	3,137	23%	709
45, 4	9	39%	3

The data shows that there are over 45,000 40-foot and 45-foot wood poles in the distribution system that are potentially structurally overloaded due to the pole attachments. The pole failures will be more common with the older poles in the system.

Figure 4-5 is a 40-foot, Class 4 pole set in 1979. Based on the pole size and number of attachments, TRC believes this pole is structurally overloaded and should be replaced with a standard wood pole.

Figure 4-5. Structurally Overloaded Eversource Class 4 Wood Distribution Pole



Source: Eversource

Figure 4-6 is a 30-foot pole set in 1938. The pole brand could not be found, so the class is unknown and likely to be Class 4 or smaller. Based on pole age and number of attachments, TRC believes this pole is structurally overloaded and should be replaced with a standard wood pole.

Figure 4-6. Structurally Overloaded 80+ year-old Eversource Wood Distribution Pole



Source: Eversource

4.1.2 Pole Maintenance and Capital Programs

The Eversource Maintenance Program – 5.61 Wood Poles, provides the procedure for the inspection, treatment (further explained in the Section 5.1.2), restoration and replacement of wood distribution poles that are owned and maintained by Eversource. It defines the schedule, inspection method, and reporting requirements for these poles. All Eversource NH poles are to be inspected at least every 10 years while they are in service. The procedure uses a pole type and age method to determine the inspection type performed, as shown in Figure 4-7 below.

Figure 4-7. Eversource Wood Distribution Pole Inspection Types

Inspection Type	Creosote, Penta, all others	CCA
Visual	0 to 9 years old	0 to 19 years old
Sound & Bore	10 to 14 years old	20 years old and older
Ground Line Excavate	15 years old and older	If decay is indicated by Sound & Bore

Source: Eversource Maintenance Program

Results of the distribution pole inspection program over the last 11 years are shown below in Figure 4-8 and indicate that the reject rate averages 2% per year. Reject poles are placed in either a normal or priority reject designation based on the criteria in the Eversource Maintenance Program –6.61 Wood Pole Inspection document. Priority reject poles are to be made safe within 10 days. The rate is in line with industry averages, but it includes all poles in the fleet that are at least 15 years old; the poles that are younger are less prone to inspection failure since they have not been in service as long. Data on the reject rate by age of pole is not available.

Figure 4-8. Eversource Wood Distribution Pole Inspection Results

Year	Poles Inspected	Reject Count	Reject Rate
2011	24,209	203	0.80%
2012	24,008	247	1.00%
2013	27,145	570	2.10%
2014	25,666	440	1.70%
2015	15,681	327	2.10%
2016	51,758	1,487	2.90%
2017	32,916	549	1.70%
2018	21,964	558	2.50%
2019	16,857	403	2.40%
2020	16,668	380	2.30%
Totals	256,872	5,164	2.01%

Source: Eversource

Based on the United States Department of Agriculture Rural Utility Services (RUS) Bulletin 1730B-121, Wood Pole Inspection and Maintenance³⁶ and other common utility practices in the same decay zone, the inspection interval should be between 10-12 years for each pole for Decay Zone 2. Figure 4-9 below shows the recommended intervals by the RUS bulletin and although Eversource meets the industry accepted wood inspection cycle, the Company does not address the issue of the aging poles.

³⁶ United States Department of Agriculture Rural Utility Services, RUS Bulletin 1730B-121, Wood Pole Inspection and Maintenance, 2013

Figure 4-9. RUS Wood Pole Inspection Program

Decay Zone	Initial Inspection	Subsequent Re-Inspection	Percent of Total Poles Inspected Each Year
1	12-15 Years	12 Years	8.3
2 and 3	10-12 Years	10 Years	10
4 and 5	8-10 Years	8 Years	12.5

Source: U.S. Department of Agriculture.

With over one-third of Eversource’s poles aged at 40 years, the inspection program should focus on older poles and include a more aggressive sound and bore or groundline excavation inspection cycle for those poles.

4.1.3 Pole Assessment Summary and Recommendations

The data above indicates two related issues regarding their wood pole plant and the equipment attached to the poles. Many of the poles (over one-third) are reaching the end of expected useful life or already beyond it and there is a greater potential for pole failure as they continue to age. While the company has experienced roughly 200 pole failures per year in recent years, this number could accelerate as the wood pole population continues to age without replacement at the same rate. While the Company has experienced roughly 200 pole failures per year in recent years, this number could accelerate as the wood pole population continues to age without replacement at the same rate. Compounding the older poles and equipment, many poles are likely structurally overloaded based on the NESC Heavy Loading Criteria and susceptible to failure during ½” ice with 40 MPH winds and other extreme weather events. This played out during Hurricane Isaias in August 2020 when Eversource lost more than 2,000 poles.

To minimize the impact of these events on system reliability, TRC recommends the following.

- 1) Establish a systematic asset replacement program to replace wood poles on an age basis, that support three phase lines, over the next 5 years. Beginning with poles 70 years and older poles, with priority on the smaller class 4, 5 and below, then address the 60- and 50-year-old poles using the same class criteria. There are about 42,000 wood poles aged 50 years and older that will need to be identified and prioritized for replacement. It is estimated that 20% (8,400) of those poles support three phase lines, requiring approximately 1,700 poles/year of the poles in this age group be replaced in conjunction with the other pole replacement efforts.
- 2) TRC recommends poles that are identified as structurally loaded at 90% or greater, be replaced with the correct sized poles to carry the mechanical load under the mandated NESC design conditions. To accomplish this, TRC also recommends that 10% (approx. 4,500) of the overloaded poles, be replaced on an annual basis. Priority should be given to the poles that are overloaded by the greatest amount and/or most critical to the system. It is also essential that all new poles that are installed have pole loading analysis completed to ensure the design criteria is met. Individual pole loading analysis will need

to be performed on all angle, tap and dead-end poles. Typical tangent pole analysis can be modeled to promote efficient design.

- 3) Continue the practice to use a minimum of Class 2 wood poles for all applications and ensure that NESC pole loading requirements are met for both the heavy loading and extreme wind scenarios. Based on analysis of the representative data, Class 2 wood poles are half as likely to be overloaded with attachments compared to Class 3 poles.

4.2 Substation Transformers & Breakers

Eversource operates 124 distribution substations across its New Hampshire service territory, serving a total of approximately 528,000 customers. Each substation typically contains 1-2 transformers, with 207 distribution power transformers across the system in total. Their system across New Hampshire also contains 523 distribution circuit breakers.

Substation Transformer Assessment

These substations represent another critical portion of system infrastructure with a growing number of aging assets. Figure 3-8 below shows the distribution of substation transformers within the distribution system based on the decade manufactured. The system currently includes 45 transformers (22%) that are over 60 years old, and 51 transformers (25%) between 50 and 60 years in age. Transformer loading is typically the primary driver for station transformer replacement, although transformer age and condition should be considered too, as shown in Figure 5-43 and discussed further in Section 5.3.

Figure 4-10. Eversource Substation Transformers by Decade Manufactured

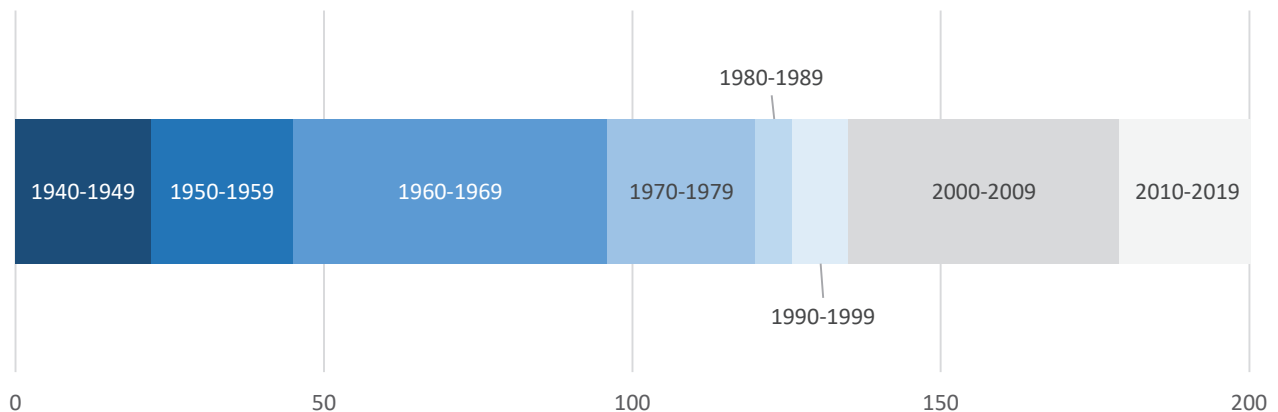

Source: Eversource New Hampshire Substation Transformer Database

Aging transformers can pose a risk to reliability if they are not properly maintained and have been overloaded over the years. Transformers have a typical design life of 25-40 years.³⁷ There

³⁷ IEEE, Standard for General Requirements for Liquid-Immersed Distribution, Power, and Regulating Transformers (C57).

are 120 transformers within the system that are exceeding the maximum typical design life of 40 years. Though some transformers operate effectively without any significant signs of a replacement being needed beyond the design life, it is necessary to maintain them properly. There are also 45 transformers over the age of 60 years and another 55 transformers that will be reaching that age in the next 10 years. TEPCO has established a life expectancy of 65 years for extra-high voltage/HV transformers and 75 years for distribution transformers, as these are the time periods when winding clamping force begins to decrease, causing a marked influence on mechanical performance. However, as the life expectancy of a transformer subject to rapidly decreasing degree of polymerization because of high-water content in the paper insulation or where the risk of failure has been established, premature replacement of the transformer is necessary.³⁸

Substation Breaker Assessment

Substation breakers are generally newer than transformers, with almost 60% manufactured since 2000 breaker assets across the distribution system. Only 13%, or 67 substation breakers date prior to 1960. Figure 4-11 below provides additional detail regarding the manufacture date of substation breakers.

Figure 4-11. Eversource Substation Breakers by Decade Manufactured

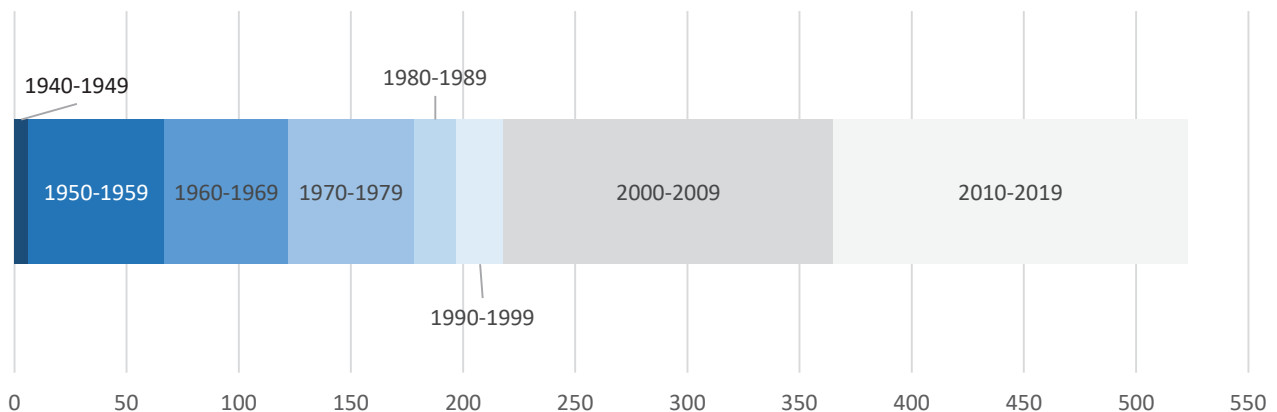

Source: Eversource New Hampshire Substation Breaker and Recloser Database

Eversource’s substations use four different types of breakers. Approximately 50% of the 523 breakers in the system use current standard vacuum (VCB) technology. The remainder of the breakers are comprised of primarily oil (OCBs) and air circuit breakers (ACBs). Figure 4-12 below represents the number of breakers within the system by equipment type:

³⁸ Shimomugi, Kojiro, et al. “How Transformers Age.” *T&DWorld*, 21 Feb. 2019, www.tdworld.com/substations/article/20972255/how-transformers-age.

Figure 4-12. Eversource Substation Breakers by Type

Vacuum	SF6	Oil	Air
244	67	90	88

Source: Eversource New Hampshire Substation Breaker and Recloser Database

Since 2005, 221 VCB’s have been installed across New Hampshire. VCB’s have been used to replace aging and obsolete assets such as Oil Circuit Breakers (OCB) and air circuit breakers (ACB). These older oil and air breakers are becoming obsolete due to availability of replacement parts as well as not being able to upgrade to new control systems within some substations. If an aging breaker is experiencing issues with operation or is unable to be maintained properly, it will warrant a replacement. Breakers are mainly replaced in conjunction with other major projects that are going on within a substation.

Substation Assessment Summary and Recommendations

TRC recommends analyzing aging station transformers and breakers. The Company should follow the transformer system violation ranking as shown in Figure 5-43 but the quantity of aging transformers needs to be taken into consideration. Age should still not be the sole driving factor for a replacement, but any transformer that has seen a larger load and use during its life should be higher on the priority list. A transformer replacement program is recommended that addresses the aging assets in conjunction with future loading projections.

TRC recommends breakers be replaced due to age if they are becoming obsolete or test results are showing excessive internal degradation. Obsolete breakers create issues with maintenance, inventory of spare parts, as well as integration with new controls. Failure of oil circuit breakers will lead to both reliability and environmental issues, so replacing these with the current standard vacuum circuit breakers is recommended. If the breakers are not posing an immediate threat to reliability, it is recommended to address breaker replacements in coordination with other station upgrade projects.

5. Eversource Distribution System Assessment Practices, Findings, and Recommendations

This section details the findings of TRC's assessments of distribution engineering materials and equipment, substations, and vegetation management practices. For each area of focus, the section reviews current practices, typical usage and installation, industry research findings, business case and cost analysis, and recommendations.

5.1 Distribution Engineering Materials and Equipment

5.1.1 Steel Poles

Current Practices

Prior to 2019, Eversource's distribution engineering standards specified the use of wood poles for all distribution line construction and maintenance. In October 2019, the Company reviewed its distribution engineering standards for distribution poles and implemented distribution class weathering steel poles as the new standard for all new and rebuilt distribution line construction in the off-road Right-Of-Way (ROW), from 4kV up to 34.5kV.

The Overhead Distribution Standards³⁹ specify requirements for the design and construction of distribution class steel poles. The poles are to be installed in the off-road ROW when a wood pole for three phase circuits is replaced at end of life or due to failure. Steel poles are not specified for single phase circuits or service poles. The Company has installed 189 steel poles for new or rebuilt distribution lines since 2018. It should be noted that steel distribution structures have been used in the ROW applications as cost beneficial alternatives for over 100 years.

During interviews with TRC, the Company's SMEs indicated the decision to update this standard was driven by a variety of advantages steel poles provide over wood poles alternatives. These advantages include:

- Greater longevity
- Ease of construction due to less weight
- Superior material design characteristic predictability
- Differing failure mode resulting in reduced catastrophic failures
- Improved reliability in severe weather events
- Lower maintenance cost

This change to the pole standard was also precipitated by an increase in severe weather events since 2008. Severe weather events have led to a sustained level of pole failures due to

³⁹ Eversource, Overhead Distribution Standards Section 10, DTRs 10.620-642.

vegetation falling into the lines, the physical overloading of poles brought on by ice loading, and windstorms resulting in 689 pole failures since 2018.⁴⁰ Given the incidence of replacements required by these failures and the difficulties of replacing these poles in remote off-road ROW settings, the standards were updated to reduce the number of pole replacements due to failure. To date, no known failures of the distribution steel poles have occurred on the Company's distribution system.

Typical Usage and Installation Practices

Distribution class steel poles are available in Class 1, H1, H9⁴¹ and used for three phase circuits. Steel poles are drilled and prepared in the field to accommodate framing, equipment, and guying holes per the design standard. Poles are accessed from bucket trucks, if that option is available, but they do accommodate removable climbing steps to be used as needed. The standards allow for reclosers, risers and other devices to be installed on the steel poles. The pole lines in the ROW can be in rough terrain that is inaccessible by vehicle and pose unique construction and maintenance design and access issues. Outages on these lines can be longer because of these access and construction challenges. Benefits and disadvantages will be addressed in the Industry and Other Utility Findings section below.

Figure 5-1. Eversource Structure Replacement, Circuit 3614



Source: Eversource

⁴⁰ Eversource NH Storm Data

⁴¹ Sabre Industries Wood Pole Equivalents

Industry Findings

Wood poles have been the standard distribution system support structure for over 100 years. They provide a readily available resource to build, maintain and operate the system. Over the past 25 years, new innovations in distribution pole types have led to an increase in standards specifying steel (and fiberglass) poles instead of wood poles. While steel poles have a higher initial cost, they provide greater durability, strength, predictability, and require less ongoing maintenance⁴². In addition, from an installation perspective, steel poles are lighter and easier to construct than wood poles.

Light duty distribution class steel poles have been the most prevalent standard distribution pole in the West and Southwestern regions of the USA over the last 20 years. These poles are specified to provide line hardening capabilities to combat high winds, wildfires and extreme ice loading conditions that have increased in frequency. Light duty steel poles are the standard distribution pole for utilities such as APS, Dominion Virginia Power, TEP, San Diego Gas and Electric, Austin Energy, and several Cooperatives throughout the USA. These utilities have experienced improvements in their construction and maintenance costs and system resiliency⁴³ as outlined in the business case below.

There have also been reports, including one from prepared by the President's Council of Economic Advisors and the U.S. Department of Energy's Office of Electricity Delivery and Energy Reliability, advocating for upgraded poles and structures with stronger materials as a primary strategy. This study specifically states⁴⁴:

"For distribution systems, this usually involves upgrading wooden poles to concrete, steel or a composite material and installing support wires and other structural supports."

Steel poles are recognized by the industry as a key component to building a robust and resilient distribution system.

Business Case

Considerations for the standard use of steel poles compared to wood poles is outlined below:

- **Longevity:** Steel poles are proven to have a longer life than wood poles due to the inherent nature of the materials. Wood poles degrade and lose strength at a much higher rate due to the susceptibility to failure from decay, insects, and animals. Based on industry information, the projected life of a wood pole is 30 to 45 years or more depending on the installation environment. Steel poles have a projected life of 90 years

⁴² Michigan Technological University, Age-Dependent Fragility and Life-Cycle Cost Analysis of Timber and Steel Distribution Poles Subjected to Hurricanes, Salman 2014.

<https://digitalcommons.mtu.edu/cgi/viewcontent.cgi?article=1779&context=etds>

⁴³ Steel Utility Pole Coalition, Case Studies. <https://steelpowerpoles.com/library/case-studies/>

⁴⁴ Economic Benefits of Increasing Electric Grid Resiliency to Weather Outages -Executive Office of the President, August 2013 Page 13

https://www.energy.gov/sites/prod/files/2013/08/f2/Grid%20Resiliency%20Report_FINAL.pdf

and likewise remain in service longer depending on the installation environment. Steel poles are also susceptible to degradation due to corrosion and galvanic losses. This degradation occurs at a slower rate can be mitigated by pole coatings.⁴⁵

- **Constructability:** Steel poles are lighter in weight, easier to handle and can cost less to install. Steel poles are 50 to 70% lighter⁴⁶ than equivalent class wood poles allowing for lighter duty equipment to perform handling and construction activities. It is a common practice for manufacturers to pre-drill holes for typical framing, equipment, and down guy configurations, thereby eliminating the time required to drill holes in the field, if that option is chosen. In Eversource's off-road installation environment, the installation of the steel and wood poles is the same. In remote areas that have limited or no vehicle access, helicopter pole sets are required. The weight advantage of steel poles includes the flexibility to utilize lighter duty helicopters to perform the pole sets that are less costly and increase the speed of the pole set.
- **Material Characteristic Predictability:** Steel, as a material, has more predictable design parameters than wood. For design purposes, the National Electric Safety Code (NESC)⁴⁷ accounts for the greater variability of wood pole composition by using higher design safety factors than are used for steel poles. Wood pole strength safety factors are 0.65 (Grade B) and 0.85 (Grade C) as compared to 1.0 (Grade B & C) for steel. Because wood strength declines significantly over time, this degradation has to be accounted for when performing pole loading analysis for future attachments and modifications.
- **Failure Mode:** In TRC's experience, steel poles do not typically fail catastrophically. They maintain form and lean over based on the causal factor. If a tree falls onto a steel pole line, the poles typically kink and/or bend and can remain in service, unless other components (crossarms, conductor, insulator, etc.) fail as well.⁴⁸ The same holds true with steel poles that fail due to excessive wind or ice load, where the poles typically lean but do not go to ground. Wood poles can, and often do fail catastrophically. Wood poles typically break at the point of pressure or the pole's weak point, and if the damage is severe enough, go completely to the ground with all attachments, causing service interruption and potentially endangering persons and property in the area due to downed lines. The Company's steel poles standards in the ROW reduces both the chance of catastrophic failure and related safety concerns.

⁴⁵ Salam, Age-Dependent Fragility and Life-Cycle Cost Analysis of Timber and Steel Distribution Poles Subjected to Hurricanes

⁴⁶ Eversource Wood and Steel Pole Standards

⁴⁷ 2017 National Electric Safety Code Section 250, General Loading Requirements and Maps

⁴⁸ UC Synergetic, Structural Analysis of Distribution Designs Northeast Utilities – Final Report. December 30, 2013

Figure 5-2. Illustrative example of wood pole failure due to ice loading



Source: Courtesy of Intelli-pole.com

- Reliability:** Distribution lines are designed to meet the regional requirements dictated by the NESC for poles, attachments, wind, ice, equipment, clearances, etc. Designs for steel distribution lines in New Hampshire also must take into consideration forested areas and the potential for trees to fall onto energized lines. These events can cause long outages due to limited or difficult access to the outage event. One study conducted by UC Synergetic found that often the pole failure is the weak link causing extended outage durations. This study found that specifying Class 1 poles would reduce these events.⁴⁹ Furthermore, steel poles would reduce the risk of catastrophic failure as described in the Failure Mode bullet above. The standardized implementation of steel poles has been in place for over two years and limits the ability to measure any impacts to distribution system performance.

The primary drawback of steel poles is their higher initial cost compared to an equivalent wood pole. Individual steel pole generally cost 2.5 to 4 times the cost of wood poles. However, the total installed cost for construction of lines with steel poles tends to be less than similar construction using wood poles due to the weight difference between the poles. These costs and savings will be further detailed in the Cost Analysis section below.

Cost Analysis

The cost analysis is based on life cycle costs. This method accounts for the initial cost to build the poles and any cost to maintain and replace them based on the equipment's useful life. The following parameters are built into the cost analysis model for the steel pole evaluation:

⁴⁹ UC Synergetic, Structural Analysis of Distribution Designs Northeast Utilities – Final

- 45'- Class 2 Wood pole life 45 years (2 wood poles will be modeled)
- 45'- Class 1 Weathering Steel pole life 90 years⁵⁰
- Wood Pole Visual, Sound and Bore or Partial Excavation Maintenance at 10-year intervals @\$13.29/test
- Steel Pole Visual inspection at 10-year intervals @ \$5.36/inspection
- Escalation costs 3% labor and materials annually
- Escalate 4% annually for wood products based on lumber index over last 40 years
- Installation in off-road ROW location

Eversource follows a 10-year visual, sound and bore, or partial excavation wood pole inspection program for all poles including the poles in the off-road ROW. Inspections are visual only up to 9 years and require a sound and bore test or partial excavation at year 10 and every 10-year interval thereafter. Steel poles do not have an equivalent intrusive inspection and only require a visual inspection as part of the line patrol. The escalated cost to maintain the 10-year maintenance cycle for both the steel and wood poles is included in the model.

Figure 5-3. Total lifecycle cost Analysis of 45-foot steel and wood poles

Project	Initial Cost	Year 10	Year 20	Year 30	Year 40	Wood Pole Replacement (45 years)	Year 50	Year 60	Year 70	Year 80	Lifecycle Total	Present Worth
45-1 Steel Pole Hendrix	\$ 6,924.36	\$ 7.20	\$ 9.68	\$ 13.01	\$ 17.48	\$ -	\$ 23.50	\$ 31.58	\$ 42.44	\$ 57.04	\$ 7,126.29	\$ 25,935.62
Labor	\$ 2,262.00	\$ -	\$ -	\$ -	\$ -	\$ -	\$ -	\$ -	\$ -	\$ -	\$ 2,262.00	
Materials	\$ 2,401.00	\$ -	\$ -	\$ -	\$ -	\$ -	\$ -	\$ -	\$ -	\$ -	\$ 2,401.00	
Overhead	\$ 2,256.00	\$ -	\$ -	\$ -	\$ -	\$ -	\$ -	\$ -	\$ -	\$ -	\$ 2,256.00	
Maintenance	\$ 5.36	\$ 7.20	\$ 9.68	\$ 13.01	\$ 17.48	\$ -	\$ 23.50	\$ 31.58	\$ 42.44	\$ 57.04	\$ 207.29	
45-2 Wood Pole Hendrix	\$ 5,189.94	\$ 42.92	\$ 57.69	\$ 77.53	\$ 104.19	\$ 20,419.49	\$ 140.02	\$ 188.18	\$ 252.90	\$ 339.87	\$ 26,812.72	\$ 19,260.36
Labor	\$ 2,262.00	\$ -	\$ -	\$ -	\$ -	\$ 8,553.97	\$ -	\$ -	\$ -	\$ -	\$ 10,815.97	
Materials	\$ 934.00	\$ -	\$ -	\$ -	\$ -	\$ 4,325.24	\$ -	\$ -	\$ -	\$ -	\$ 5,259.24	
Overhead	\$ 1,962.00	\$ -	\$ -	\$ -	\$ -	\$ 7,419.49	\$ -	\$ -	\$ -	\$ -	\$ 9,381.49	
Maintenance	\$ 31.94	\$ 42.92	\$ 57.69	\$ 77.53	\$ 104.19	\$ 120.78	\$ 140.02	\$ 188.18	\$ 252.90	\$ 339.87	\$ 1,356.02	

Results show the cost of the steel poles are more cost effective than similar wood poles when longevity and maintenance costs are considered in the total lifecycle of the pole. It should be noted that the Net Present Worth Analysis was performed using the same input data and the results showed that the steel pole has a 35% greater present worth than the wood pole over the life of the pole.

Recommendations

Poles are a major infrastructure investment. Life cycle cost analysis offers a broader perspective of costs over time. Based on the above analysis, industry and environmental trends, steel distribution poles are an investment that provide a long-term solution for safe, reliable, and cost-effective service to the customer. This investment is one component of improved distribution line resiliency. Steel poles used in off-road right-of-way settings provide additional resiliency benefits to guard against what would be a longer duration outage, given the difficulty in patrolling and replacing these more remote assets in the event of a failure during a severe

⁵⁰ Eversource has steel transmission structures that have been in service for over 100 years.

weather event. EPRI notes that this type of selective equipment application is often the most appropriate for grid hardening investments:⁵¹

“There is no ‘silver bullet’ that enables utilities to substantially eliminate interruptions during severe weather events. Utilities need to identify potential resiliency solutions, determine the costs, and added value associated with each solution, and then select a combination of solutions that best serves all stakeholders. Hardening solutions, with the possible exception of vegetation management solutions, are generally not cost effective for universal application throughout a utility’s electric system. Hardening options need to be selectively applied based on careful consideration of the costs and benefits expected for each utility system, regional demographics, environmental characteristics, and other factors.”

The combination of steel poles in off-road ROW applications along with larger class standard wood poles, spacer cable and fiberglass crossarms are together distribution equipment hardening solutions that provide greater reliability and resiliency. The current practice installs steel poles in the ROW to replace existing wood poles or obsolete steel lattice towers (such as circuit 3178X3) that are either damaged or at end of life.

TRC recommends adding a proactive program to replace wood poles or obsolete steel lattice towers in the ROW on a planned basis in addition to the current practice. The plan should include a minimum of five circuit miles of off-road ROW, three phase rebuilds, including rebuilds that are part of the inaccessible line relocation projects. Line projects need to be prioritized by reliability performance and susceptibility to damage or failure from trees.

5.1.2 Class 2 Wood Poles

Current Practices

Eversource historically stocked and specified Class 3 or 4 wood poles for distribution line construction and maintenance of facilities. In 2016, Eversource changed the pole standard to Class 2 wood poles as the minimum class pole for all primary poles installed. This change was precipitated by a need to provide enhanced storm hardening capabilities⁵² and to gain consistency with standards for wood poles.

As with the ROW installed steel poles, spacer cable and fiberglass crossarms, the system hardening needs were driven by an increase in severe weather events since 2008, as shown in the Eversource NH Major Storm Events report. These types of events have led to a sustained level of pole failures (689 pole failures since 2018, roughly 200 per year) due to vegetation falling into the lines and the physical overloading of poles brought on by ice loading and windstorms. Given the persistent pole replacements brought on by these failures, the standards were updated to Class 2 poles to reduce the number of failures causing outages and emergency replacement.

⁵¹ Electric Power Research Institute, Distribution Grid Resiliency: Prioritization of Options, 2015. <https://www.epri.com/research/products/3002006668>

⁵² UC Synergetic, Structural Analysis of Distribution Designs Northeast Utilities – Final Report

Typical Usage and Installation Practices

Eversource Overhead Distribution Standards⁵³ specify standards for the design, construction, and maintenance of distribution poles. The Distribution System Engineering Guide (Eversource Section 02.50 Reliability- Storm Resiliency Guidelines)⁵⁴ provides the instructions and guidelines to implement storm hardening practices. There has been a total of 12,941 Class 2 Chromated Copper Arsenate (CCA) treated wood poles installed in the Eversource system since 2018, ranging in length from 35' to 55'. The CCA Class 2 wood poles were installed in roadside applications as new and replacement poles for distribution voltages ranging from 34.5kV three phase to service voltages. A 45' Class 2 pole is the minimum class for three phase circuits and a 40' Class 2 pole is the minimum class for single phase circuits. Additionally, the Storm Resiliency Guidelines specifies that all junction poles are to be a minimum of a Class 1 wood pole.

The Class 2 and Class 1 (junction poles) size poles are the minimum classes to be specified in the roadside installations. If the pole application requires a larger class pole, as determined by Pole Loading Analysis (PLA) software, then a pole designed for that installation shall be specified. The PLA tool models two scenarios and uses the worst case as the final design criteria. The criteria are designed as follows:

- 1) 95 MPH Wind at 60° C with No Ice
- 2) 40 MPH Wind at 15° C with ¾" Ice

The first design criteria are based on the Extreme Wind Loading criteria as specified by 2017 NESC Rule 250C.⁵⁵ Design criteria 2 represents the Extreme Ice with Concurrent Wind Loading as specified by the 2017 NESC Rule 250D⁵⁶. Both scenarios are relevant to the Eversource system as they were experienced with Hurricane Irene and Storm Alfred in 2011.

Industry Findings

As stated in the Distribution Class Steel Pole section of the report, wood poles have been the standard distribution system support structure for life of the distribution industry. Wood poles are relatively inexpensive compared to other alternatives (steel, concrete, fiberglass) but are prone to unseen imperfections and deterioration due to insects, animals and fungus making the design and longevity less predictable than other alternatives.⁵⁷ Eversource has distribution facility attachments to about 455,000 distribution poles with maintenance responsibility for about 276,000 of those poles⁵⁸ making up their distribution pole fleet. The wood pole integrity and strength play a pivotal role in reducing the number and duration of outages on the distribution system.

⁵³ Eversource, Overhead Distribution Standards, Section L3-OH05, DTRs 101-309.

⁵⁴ Eversource, Reliability – Storm Resiliency Guidelines, 2016.

⁵⁵ 2017 National Electric Safety Code, Section 250C.

⁵⁶ 2017 National Electric Safety Code, Section 250D.

⁵⁷ Salam, Age-Dependent Fragility and Life-Cycle Cost Analysis of Timber and Steel Distribution Poles Subjected to Hurricanes

⁵⁸ Direct Testimony of Purington and Lajoie)

The increase of significant storm events in the USA and specifically in the Northeast has prompted utilities to look for ways to determine optimal designs for storm resiliency for the distribution system. Two comprehensive studies were conducted in 2013 and 2015 that address recommended practices regarding the larger class wood poles in addition to other system improvements (insulators, crossarms, spacer cable, etc.) that can be implemented to reduce the impact of the storms and improve reliability overall.

The first study conducted in 2015 by the Electric Power Research Institute, titled Distribution Grid Resiliency: Overhead Structures⁵⁹, was a three-year, multi-deliverable research project, addressing methods to evaluate hardening solutions to improve distribution grid performance related to major weather events. The study had participation and input from 27 electric utilities throughout the USA and included field testing of actual structures (poles, trees, or other structural load) falling or structurally imposed on distribution pole lines to measure the impact on the withstand capabilities of the poles, conductors, crossarms, down guys and other equipment installed on the distribution poles. The EPRI report provides detailed findings associated with each component scenario tested. A summary of the study results concluded that the pole top circumference was the largest determining factor for the performance of the poles subject to dynamic stresses, such as tree impacts on distribution lines. Performance in terms of energy increases as a function of the top circumference to at least the fourth power. In the case of a 40' Class 4 pole (31.5" circum.) versus a 40' Class 2 (38.5" circum.) pole, the Class 2 pole impact force withstand capability will be approximately 60% greater than the Class 4 pole.

The second study was conducted by UC Synergetic in 2013 and titled Structural Analysis of Distribution Designs – Northeast Utilities.⁶⁰ The overview states that the study is to perform structural analysis on a variety of distribution wood pole structure designs so that a quantitative analysis can be developed to optimize designs for storm resiliency. This study also looked at the impact of trees falling on lines and the ability to withstand ice loading. All analysis was based on PLS-CADD™ models for all components of a distribution line including poles, conductor, crossarms, insulators and other structural supports. The analysis modeled simulations of trees falling onto distribution lines for the following scenarios:

- NESC Heavy Loading (1/2" Ice at 40 MPH Wind)
- 1/2" Ice at 0°C
- 3/4" Ice at 15°C
- 95 MPH wind at 60°C

These parameters fit very closely to the Eversource Storm Resiliency Guidelines. Conclusions are as summarized.

⁵⁹ EPRI, Distribution Grid Resiliency: Overhead Structures, December 2015.
<https://www.epri.com/research/products/000000003002006780>

⁶⁰ Salam, Age-Dependent Fragility and Life-Cycle Cost Analysis of Timber and Steel Distribution Poles Subjected to Hurricanes

- Class 3 poles failed in all NESC Heavy Loading cases
- Class 2 poles passed the light tree (1,500 lbs.) simulation but failed in the heavy tree (3,840 lbs.) simulation
- Class 2 and 3 poles passed in the light and heavy tree simulations for ½” and ¾” ice
- Class 3 poles failed in 95 MPH simulation

It should be noted that during a storm event (or any outage event on a distribution line), a pole failure is the least desirable outcome, as pole replacements are typically the most difficult and costly to repair compared to replacing conductors or crossarms. Splicing conductors, replacing crossarms or insulators would be preferable to reduce costs and outage durations.

The results of the two studies present both an in-the-field and a calculated example of the benefit of larger class poles to prevent distribution line outages from trees falling on distribution lines and extreme ice and wind loading. The study’s findings complemented each and bear out that the decision by Eversource to change to a minimum of Class 2 wood poles will reduce distribution line outages.

Business Case/Cost Analysis

The information contained in the two studies constitutes the majority of the business case for the specification of a Class 2 wood pole as the minimum size, with the exception of the financial consideration. The table below shows the installed cost of the typically used pole sizes comparing the Class 3 with the Class 2, provided by Eversource.

Figure 5-4. Comparison of wood pole installed costs by size and class

Pole Size (Southern yellow pine, CCA treated)	Class 3 Installed Cost	Class 2 Installed Cost	Class 2 Cost Differential
40 ft length	\$1,403	\$1,440	+2.6% (\$37)
45 ft length	\$1,475	\$1,540	+4.4% (\$65)
50 ft length	\$1,554	\$1,586	+2.1% (\$32)

Source: Eversource internal data

The installed cost difference between Class 3 and Class 2 poles is relatively small and the improvement in reliability (SAIFI and SAIDI) realized by using the stronger Class 2 poles coupled with the avoided cost of broken pole replacement, should quickly offset the incremental cost difference. In the case of Eversource, during 2018 storm events, the Company replaced 175 poles. The cost increase for using Class 2, 45-ft poles in these events would be \$11,375. If just eight poles, or 5%, had not failed due to use of the stronger Class 2 poles, the cost savings would be justified.

Figure 5-5. Eversource count of broken poles caused by storms from 2018-2021

Storm Year	Replaced Poles
2018	175
2019	255
2020	180
2021-Q1	58

Source: Eversource internal data

From an operational perspective, reducing the number of pole classes needed in inventory by specifying a minimum of Class 2 poles provides the opportunity for better purchase prices, less warehousing costs, and the ability to share pole resources across distribution networks depending on localized needs.

Figure 5-6 below shows an example of a 45' Class 2 wood pole installed in 2018 with a three-phase line and multiple third-party attachments.

Figure 5-6. Example of Class 2 wood pole with fiberglass crossarm



Source: Eversource

Recommendations

The use of higher-class poles (Class 2) has been shown to prevent and reduce the outage impacts brought on by trees falling on distribution lines, heavy ice loading, and extreme wind situations experienced throughout the United States. The Company has seen a regular occurrence of major event outages causing greater chances for prolonged outages since 2008. Using Class 2 wood poles as a minimum size can reduce the number and severity of the outages with a minimal cost difference over Class 3 poles.

Based on the review of Eversource's pole standards, cost analysis and industry information, standardizing road-side distribution construction and emergency replacement utilizing Class 2 poles, within the PSNH service territory, is sound engineering judgement and within good utility practices.

5.1.3 *Spacer Cable*

Current Practices

Eversource has been using spacer cable for several decades and made it the standard overhead conductor in 2015.⁶¹ Since 2015, the Company has installed approximately 386 miles of 35 kV spacer cable. Although there are no formal plans to replace all open wire bare conductor with spacer cable, current design guidelines established in 2016 specify the use of spacer cable for all new three-phase primary distribution lines. Spacer cable continues to be used to replace open-wire bare primary on a case-by-case basis to improve performance and reliability of specific areas. Tree wire is used on a limited basis for single phase laterals and will not be addressed in this report.

The implementation of the Eversource Storm Resiliency Guidelines in 2016 was a strategic response to outages due to an increase in severe weather events that occurred prior to 2016. These events, comprised of wind and ice storms, had led to an increase in widespread tree related outages, and in many cases, severe damage. The guideline recommendations covered the increased use of steel poles, Class 2 wood poles, spacer cable, fiberglass crossarms, and other solutions covered in this report.

Eversource staff indicated the 2016 design guidelines, that expanded the use of spacer cable, were driven by a variety of advantages over the use of open wire bare conductor designs. These advantages include:

- Minimized temporary faults due to tree branches and incidental animal contact
- Ability to survive larger tree and limb falls while remaining in-service
- Less space required on the pole than an open wire design, minimizing ROW requirements
- Smaller tree trimming envelopes

⁶¹ Interview with Eversource Standards Group, March 18, 2021

- NESC Rule 230D, Covered Conductors⁶² compliant

Typical Usage and Installation Practices

Eversource has standardized the following spacer cable sizes. Each of these insulated cables are covered in a rugged polymer jacket:⁶³

- 795 mcm AAC (all aluminum conductor) 35 kV and 15 kV (Standard)
- 556 AAC 25/30 kV
- 477 mcm AAC 35 kV and 15 kV (Standard)
- 336 mcm AAC 25/30 kV
- 1/0 ACSR/AW (aluminum cable, steel reinforced with an Alumoweld core) 35 kV, 25/30 kV and 15 kV (Standard)

The Company purchased several high-strength messenger wire types, but the 052 AWA is the most used. The 052 AWA is a bare wire, and the description indicates it is a 7-strand wire having 5 strands of Alumoweld wire and 2 strands of aluminum wire. The combined cable is electrically equivalent to 1/0 aluminum. The messenger wire is the system neutral, except in rare situations that may require a separate neutral wire.

The spacers and the anti-sway bracket are made of track resistant UV protected polymer. The spacers have four integral clamps for the cables and messenger wire. The clamps can be opened and closed if needed to temporarily remove a cable from the spacer to allow for repairs or for splicing.

⁶² 2017 National Electric Safety Code Section 230D

⁶³ Eversource Energy Material Standards MAT C-2

Figure 5-7. 35 kV MGY and Below – Spacer Cable Construction Tangent and Small Corner

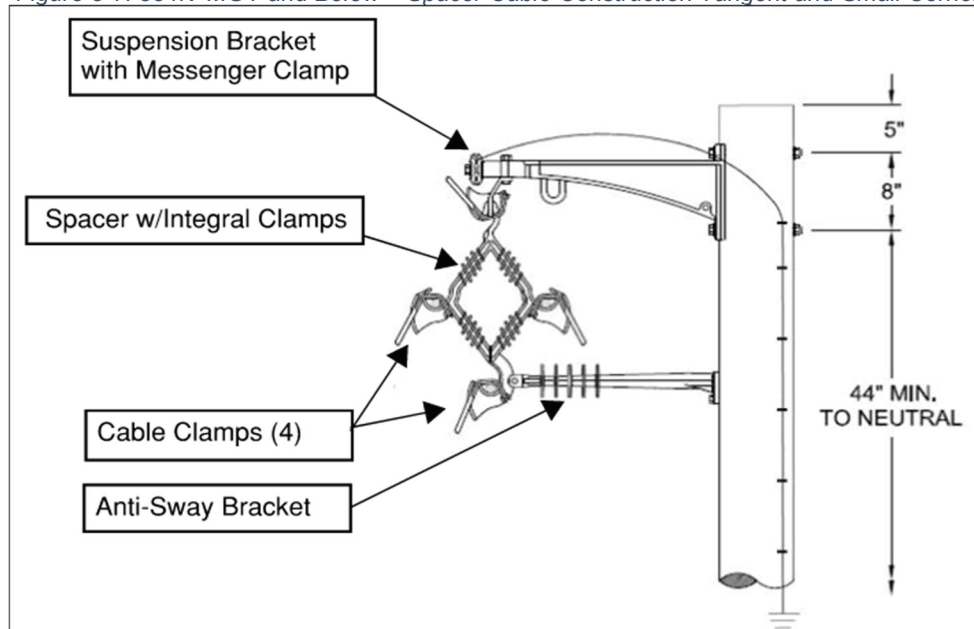

Figure 5-7 above from Standard DTR 10-738 illustrates a 35 kV three phase spacer cable tangent pole and components. The three 35 kV cables are clamped into their positions on the spacer and the spacer is suspended from the messenger wire. The messenger is then installed and secured to the metal suspension bracket. The anti-sway bracket is used to restrict the movement of the spacer cable assembly and is not used on every pole.

Industry and Utility Findings

Spacer cable was invented in the 1950's and has been in use industry-wide for several decades. It is an established, readily available component used to enhance system resiliency and reliability.⁶⁴ According to Hendrix - Kerite Wire and Power Cable, spacer cable is used by over 50 investor-owned utilities, such as National Grid, Avangrid, AEP, Georgia Power, PG&E, Entergy, and over 75 Cooperatives and Municipals throughout the USA and is commonly reflected in their distribution standards. TRC has direct design experience with many of the utilities that specify spacer cable for their distribution system.

Spacer cable installations have been the most prevalent in forested areas throughout the USA. They are specified to enhance the system to combat tree related outages resulting from high winds and ice loading conditions. It is also used in congested alley ways and along busy streets to improve clearances to buildings, signs, and other structures. Spacer cable is not limited to short span situations. River crossings in excess of 1500 feet have used spacer cable to provide clearance over water for sail boats and commercial river traffic.

⁶⁴ EPRI, Distribution Grid Resiliency: Overhead Structures.

Business Case

As noted above, spacer cable has several important benefits compared to open wire bare conductor designs. The first two directly address tree-related outages, which is the leading cause of outages at Eversource. The Company has seen a decrease in both SAIFI and SAIDI over the ten-year period ending in 2020. It is not possible at this time to determine how much of that decline is attributed specifically to spacer cable, but it is a component of the overall resiliency program along with other equipment addressed in this report.

For additional information on spacer cable and other active resiliency/reliability methods and metrics, refer to the IEEE Report PES TR83 “Resiliency Framework, Methods, and Metrics for the Electricity Sector” published in 2020⁶⁵, see especially Section 6.1 on page 22.

Benefits associated with spacer cable are:

- **Spacer cable minimizes temporary faults due to tree and incidental animal contact.** Spacer cable is an insulated cable constructed with a thick UV protected polymer jacket; tree branches, twigs, etc. that fall across phases do not result in recloser operations or sustained outages. The same holds true for branches laying across the messenger and phase. Animal related outages, those due to metalized balloons, vandalism, etc. are also minimized for the same reason. Furthermore, these objects can be removed during normal working hours thus avoiding an overtime callout. In some cases, a bucket truck is not needed, just a line mechanic with hook stick. Figure 5-8 below shows outages with bare wire compared to spacer cable installations for Northeast Utilities over a five-year period. Overall, spacer cable has been attributed to a 75% outage reduction for this study.
- **Spacer cable has a demonstrated ability to survive larger tree and limb falls⁶⁶⁶⁷.** Spacer cable does have its limits and there are trees and limbs heavy enough to break the messenger, poles, etc. However, as illustrated in Figure 5-9 and Figure 5-10 below, spacer cable has a higher tolerance for such events. These images show a substantial tree limb has broken away and come to rest on an Eversource spacer cable segment, without resulting in an outage. Details of trees on conductor testing are included in the referenced EPRI report.
- **Spacer cable requires a smaller tree trimming envelope.** Since the cables are insulated and resistant to physical damage from tree branches, etc., tree trimming corridors along the line offer the potential of being reduced in width. Figure 5-11 below shows the Eversource 8 Foot clearance zone spec. Note that with a 10 ft. crossarm, the clearance envelope is 26 ft. If spacer cable is used, the trimming zone is reduced to about 19 ft.
- **Spacer cable can be used to solve encroachment problems by eliminating the overhanging of energized conductors over private property.** Some property owners refuse to have trees trimmed, and spacer cable can be a solution. Figure 5-12 below is

⁶⁵ IEEE Report PES TR83 “Resiliency Framework, Methods, and Metrics for the Electricity Sector”

⁶⁶ EPRI, Distribution Grid Resiliency: Overhead Structures.

⁶⁷ UC Synergetic.

an Eversource photo showing a situation where the customer refused to allow tree trimming. This is a good example of where space cable could be utilized to reduce the risk of an outage event.



- **A spacer cable circuit occupies less space on the pole than an open wire design.** This translates into more efficient use of existing poles. For example, in Figure 5-13 below, an additional circuit was installed adjacent to the existing one using the same bolt-holes, thus avoiding a pole change-out.
- **Spacer cable is NESC Rule 230D⁶⁸ compliant.** Rule 230D allows the use of spacer cable and states the clearance between conductors of the same or different circuits, including grounded conductors, may be reduced below the requirements for open conductors when the conductor covering provides sufficient dielectric strength to limit the likelihood of a short circuit in case of momentary contact between conductors or between conductors and the grounded neutral. Intermediate spacers may be used to maintain conductor clearance and support. (See Figure 5-13)

The following photos and graphics illustrate some of the benefits of spacer cable described above:

Figure 5-8. Outages based on 100 circuit miles/year over Five years

Cause of Outage	Bare Wire		Spacer Cable	% Reduction
Tree Related	17.6		1.8	90
Animals	12.1		2.9	76
Lightning	3.4		1.0	71
Unknown	5.9		1.0	83
All Other	11.3		5.9	48
Total	50.3		12.5	75

Northeast Utilities 5 Year Statistics
Based on 100 circuit miles per year

Source: Hendrix Aerial Cable Systems

⁶⁸ 2017 National Electric Safety Code Section 230D

Figure 5-9. Photo of a tree incursion on an Eversource line using spacer cable that remained intact



Source: Eversource

Figure 5-10. Examples of spacer cable withstanding storm events to prevent outages

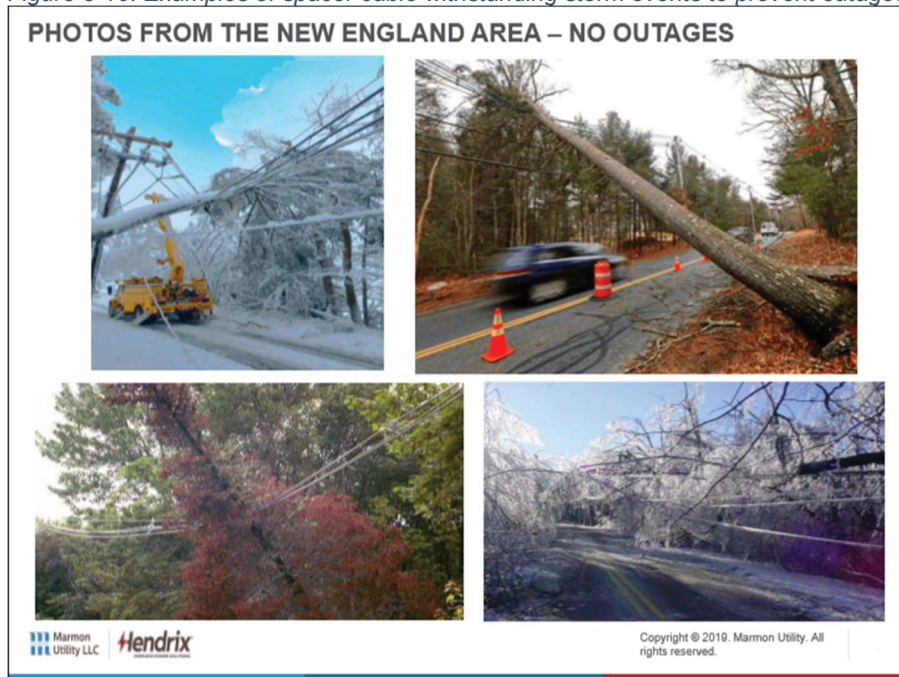

Source: Marmon/Hendrix (used with permission)

Figure 5-11. Example of enhanced tree trimming clearances needed for a typical mainline circuit; less clearance is needed for spacer cable installations due to lower profile of installations.

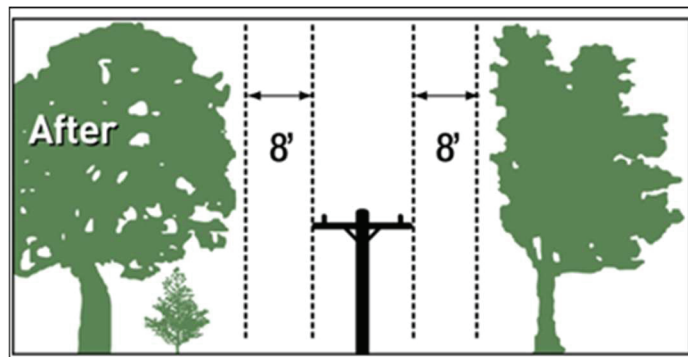

Source: Eversource ETT Specifications

Figure 5-12. Example of an open-wire cable distribution line with vegetation encroachment due to a customer's refusal to allow tree trimming.



Source: TRC Field Inspection

Figure 5-13. Image and graphic of spacer cable design showing compact nature of installations

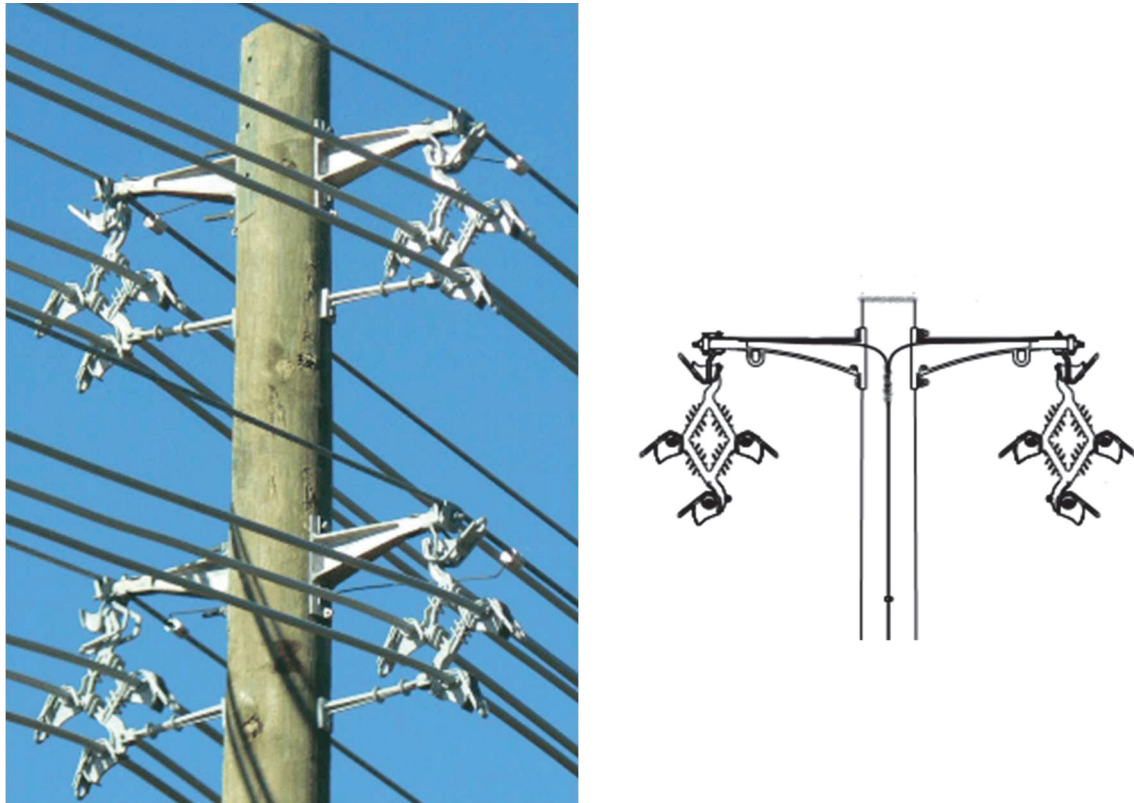

Source: Marmon/Hendrix and TRC

Cost Analysis

Spacer cable construction requires a greater upfront cost than open bare wire conductor. The two scenarios in Figure 5-14 represent the Company's estimated costs to construct a mile of a three-phase open wire bare conductor line and a mile-long spacer cable line. Both scenarios have the same periodic inspection costs for circuits built using wood pole construction. Based on TRC's experience, the total cost difference is generally consistent with vendor information and other utilities.

- 1) The benefits of using spacer cable can be attributed to directly improving system reliability and resiliency. The cost savings, as described earlier in this report, remains a critical challenge for utilities and regulators, as the benefits are difficult to monetize. Avoided costs include those incurred due to outages and maintenance and construction.

Figure 5-14. Estimate Cost per Mile of Three-Phase Open Wire Bare Conductor and Spacer Cable

	Labor	Materials	Overheads	Total
Open Wire Bare Conductor	\$24,167	\$31,238	\$47,043	\$102,448
Spacer Cable	\$44,954	\$66,684	\$93,760	\$205,398

Source: Eversource internal data

Recommendations

Spacer cable is an essential component to a comprehensive resiliency and reliability program that will also include expanded use of steel poles, stronger wood poles, fiberglass crossarms, and a robust ROW vegetation clearing program. Tree contacts remain the leading cause of outages. Despite these measures, trees will continue to fall over, and limbs and branches will continue to break, some of which are light enough to be taken by the wind into the wires. Utilities are required to obtain authorization from property owners to trim trees, and some property owners are unwilling to grant the necessary authorization. Spacer cable prevents or minimizes those tree-related outages that occur regardless of a robust ROW clearing program. Spacer cable can reduce or eliminate outages due to animals, vandalism, etc. Overtime callouts to correct these and tree related situations can be reduced.

TRC recommends the following:

- Continue the spacer cable program as outlined in the Eversource’s 2016 Resiliency Guidelines.
- As part of the capital planning process, accelerate the rebuilding/reconducting of the open wire, three phase lines that are the most susceptible to outages in heavily treed and narrow ROW areas over the next 5-years. Work in conjunction with the inaccessible line relocations to the roadside and steel pole installation projects in the steel pole section.

5.1.4 Fiberglass Crossarms

Current Practices

Eversource has been using fiberglass crossarms for approximately five years beginning around the third quarter of 2016; fiberglass crossarms were integrated into their standards at the same time.

Although there are no formal plans to replace all existing wood crossarms with fiberglass, current design guidelines in 2016⁶⁹ specify their use for all new construction and on an as-needed basis resulting from pole inspections and observations.

⁶⁹ Eversource, Reliability – Storm Resiliency Guidelines.

The implementation of the 2016 design guidelines was a comprehensive response to outages due to an increase in severe weather events that occurred prior to 2016. These events, comprised of wind and ice storms, led to an increase in tree related outages, and in many cases, severe damage. Eversource SMEs indicated the decision to update their standards to use fiberglass crossarms was driven by a variety of perceived advantages over wood arms. These advantages include:

- Improved Longevity
- Ease of Installation
- Greater Material Uniformity and Consistency
- Improved Reliability

Typical Usage and Installation Practices

The Company standardized on several fiberglass cross arm sizes. This report will focus on the 10-foot tangent and 10-foot dead-end arm, the most used size.

Fiberglass arms do not require braces as wood arms do; they are delivered with 2-hole metal mounting brackets as can be seen in Figure 5-15 and Figure 5-16 below.

Figure 5-15. 27.6kV Fiberglass Crossarm Construction, Three-Phase Small Angle/Tangent Pole

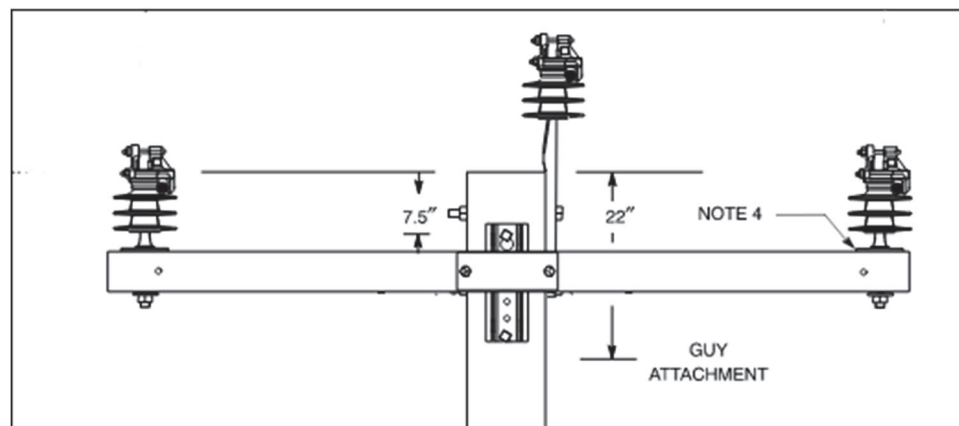

Source: Eversource Energy Construction Standard DTR 11.211

Figure 5-16. 27.6 kV Fiberglass Crossarm Construction, Three-Phase Dead-end Pole

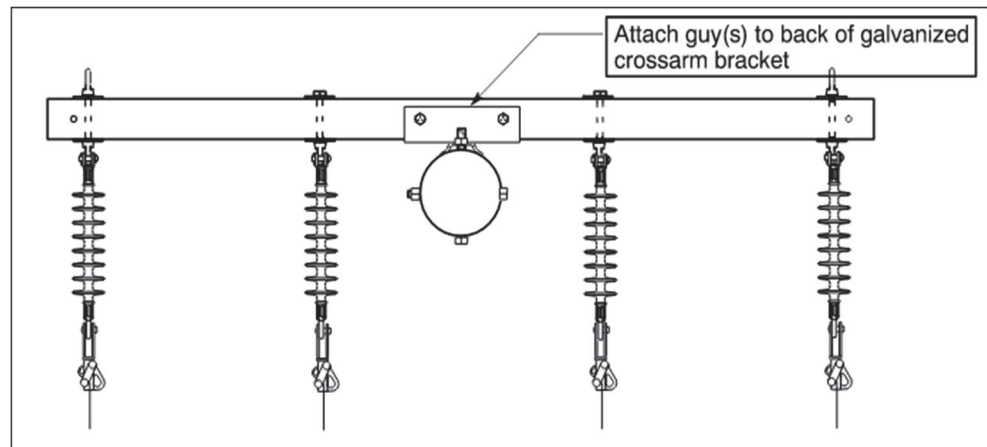

Source: Eversource Energy Construction Standard DTR 11.219

Industry and Utility Findings

The use of fiberglass crossarms began in the early 1990's; fiberglass is not new to the electric energy industry. Because fiberglass is a good electrical insulator, it has been used in products since the late 1950's such as bucket truck booms, and later, in electrical products such as guy insulators. Vendors began shipping crossarms in the early 1990's and two of the larger manufacturers claim to have delivered over 7 million crossarms since then. Many IOUs and others are now using fiberglass arms including National Grid, Avangrid, AEP, Georgia Power, PG&E, Entergy, and many Cooperatives and Municipals throughout the USA. One of the important applications is on distribution steel poles and to support distribution lines on steel transmission structures. The longevity of fiberglass arms is a good match to the longevity of steel poles.

Business Case

As noted above, fiberglass crossarms have several important benefits when compared to wood. Benefits associated with fiberglass crossarms are:

- Improved Longevity:** Fiberglass crossarms are not susceptible to decay, insect, or woodpecker damage. Fiberglass crossarms are constructed with integral UV protection, not just in the surface coating, and are considered to have a life expectancy of 60+ years according to manufacturers such as PUPI. Because of this longevity, fiberglass arms are a good match for installation on steel poles.
- Withstanding splitting and decay:** Wood crossarms are susceptible to longitudinal and end splitting, allowing moisture to collect and remain in the wood, thus promoting decay. Wood arms are often damaged by woodpeckers, insects, and weathering. Figure 5-17 below illustrates the problem, although both insects and decay were probably involved. Note that a visual inspection from the ground most likely would not have caught this.
- Ease of Installation:** Fiberglass crossarms are lighter and easier to handle, weighing just up to 1/3 the weight of wood arms. They typically do not need braces, which are necessary with comparable wood arms. Fiberglass crossarms, both tangent and dead-end, include an installed two-hole metal mounting bracket, and therefore take less time

to install on poles. The mounting bracket on the dead-end arms also includes guy attachment points, which is an advantage.

- Greater Material Predictability:** Fiberglass crossarms are an engineered, manufactured product using controlled processes and materials that offer a uniform product with consistency. Conversely, wood is a highly variable material. Even newly processed wood crossarms can have naturally occurring internal voids and defects. This variability is compensated for by applying load factors, as outlined in the NESC 253, when making strength calculations. The amount of wood preservative retained in the wood, typically pentachlorophenol (PCP)⁷⁰, lessens with time. As a result, the strength of wood crossarms degrade over time. Figure 5-18 shows the components of a typical fiberglass crossarm.

These benefits translate into improved resiliency and reliability of fiberglass cross arms compared to wood.

Figure 5-17. Insect Damage on an Eversource Wood Crossarm



Source: Eversource Photo

⁷⁰ In a March 9, 2021 article in the Chemical & Engineering News (C&EN) a publication of the American Chemical Society “The End of Pentachlorophenol is Near”, the Environmental Protection Agency (EPA) is considering banning the use of PCP as a health risk. This comes on the heels of an announcement from the only producer of PCP in North America that it was shutting down its PCP production.

Figure 5-18. Fiberglass Crossarm Composition Drawing

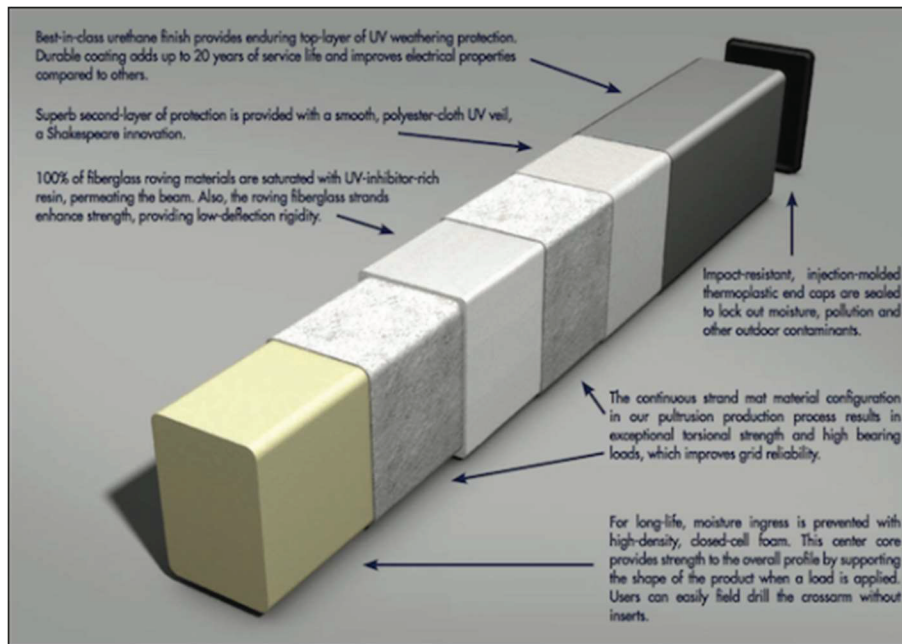

Source: Valmont/Shakespeare

Longevity and strength are the keys to reliability. As noted earlier, fiberglass crossarms have exceptional longevity, 60+ years. According to a report by Electric Power Research Institute titled *Distribution Grid Resiliency: Overhead Structures*⁷¹, fiberglass crossarms are approximately 30% stronger than wood and have superior electrical properties. This study notes that their use is now considered a common industry practice.

One study conducted to optimize designs for storm resiliency looked at a variety of distribution wood pole structure designs, as well as the impact of trees falling on lines and the ability of these structures to withstand ice and wind loading.⁷² All analysis was based on PLS-CAD™ models for all components of a distribution line, including poles, conductor, crossarms, insulators and other structural supports. The analysis modeled simulations of trees falling onto distribution lines for the following scenarios:

- NESC Heavy Loading (1/2" Ice, wind at 40 MPH)
- 1/2" Ice at 0°C and 3/4" ice at 15°C
- 95 MPH wind at 60°C

The simulations included 8 ft. and 10 ft. fiberglass and wood crossarms and found:

⁷¹ EPRI *Distribution Grid Resiliency: Overhead Structures*

⁷² UC Synergetic, *Structural Analysis of Distribution Designs – Northeast Utilities*

- For the NESC Heavy Loading case, fiberglass crossarms passed all cases, including the heavy tree simulation (3,840 lbs.). Wood crossarms failed the heavy tree simulation.
- For the ½” and ¾” icing cases, wood and fiberglass arms passed the light tree (1500 lbs.) simulation.
- For the 95 mph. wind test, fiberglass arms passed all cases, while wood arms failed in several.
- The simulations that focused on dead-end structures showed that wood crossarms were utilized to more than 80% of capacity. Fiberglass arms showed a capacity 5 times greater than wood arms.

It should be noted that during storm events, broken poles present the most challenging problems, with crossarms a close second. In some cases, special equipment, such as dozers or cranes, are needed just to deliver the normal equipment and materials to the damage site. However, replacing crossarms, installing conductor splices, pins or insulators can be less dependent on specialized equipment. In some cases, with fewer broken large components, the repair work can be accomplished by line personnel utilizing their climbing skills.

Cost Analysis

The cost analysis model below looks at both the lifecycle and present worth costs to install 10 ft. fiberglass and wood tangent arms, as well as dead-end arms, on wood poles. Additional assumptions for this analysis include:

- The life of the wood pole is assumed to be 45 years.
- Wood crossarms are expected to be replaced at 25 to 30 years.
- Fiberglass crossarms do not require replacement for the life of the pole.
- The periodic maintenance cost of \$2.14 is for a visual inspection of the installed cross arms (wood and fiberglass), which is assumed to be conducted concurrently with the periodic pole inspection.

The life-cycle cost analysis with a wood crossarm replacement midway through the life of the wood pole shows the fiberglass crossarm is a better investment over the life of the pole.

Figure 5-19. Wood and Fiberglass Crossarm Lifecycle & Present Worth Costs

Project	Initial Cost	Year 10	Year 20	Wood Arm Replacement (25-30 years)	Year 30	Year 40	Year 50	Year 60	Life Cycle Cost	Present Worth Cost
Fiberglass arm, Tangent	\$ 170.23	\$ 2.88	\$ 3.87	\$ -	\$ 5.19	\$ 6.98	\$ 9.38	\$ 12.61	\$ 211.14	\$ 538.05
Labor	\$ 12.15	\$ -	\$ -	\$ -	\$ -	\$ -	\$ -	\$ -	\$ 12.15	
Materials	\$ 122.00	\$ -	\$ -	\$ -	\$ -	\$ -	\$ -	\$ -	\$ 122.00	
Overhead	\$ 33.94	\$ -	\$ -	\$ -	\$ -	\$ -	\$ -	\$ -	\$ 33.94	
Maintenance	\$ 2.14	\$ 2.88	\$ 3.87	\$ -	\$ 5.19	\$ 6.98	\$ 9.38	\$ 12.61	\$ 43.05	
Wood arm, Tangent	\$ 96.83	\$ 2.88	\$ 3.87	\$ 337.70	\$ 5.19	\$ 6.98	\$ 9.38	\$ 12.61	\$ 475.43	\$ 318.62
Labor	\$ 18.25	\$ -	\$ -	\$ 38.21	\$ -	\$ -	\$ -	\$ -	\$ 56.46	
Materials	\$ 51.77	\$ -	\$ -	\$ 239.74	\$ -	\$ -	\$ -	\$ -	\$ 291.51	
Overhead	\$ 24.67	\$ -	\$ -	\$ 51.65	\$ -	\$ -	\$ -	\$ -	\$ 76.32	
Maintenance	\$ 2.14	\$ 2.88	\$ 3.87	\$ 8.09	\$ 5.19	\$ 6.98	\$ 9.38	\$ 12.61	\$ 51.14	
Fiberglass arm, Deadend	\$ 335.53	\$ 2.88	\$ 3.87	\$ -	\$ 5.19	\$ 6.98	\$ 9.38	\$ 12.61	\$ 376.44	\$ 1,049.28
Labor	\$ 12.15	\$ -	\$ -	\$ -	\$ -	\$ -	\$ -	\$ -	\$ 12.15	
Materials	\$ 260.00	\$ -	\$ -	\$ -	\$ -	\$ -	\$ -	\$ -	\$ 260.00	
Overhead	\$ 61.24	\$ -	\$ -	\$ -	\$ -	\$ -	\$ -	\$ -	\$ 61.24	
Maintenance	\$ 2.14	\$ 2.88	\$ 3.87	\$ -	\$ 5.19	\$ 6.98	\$ 9.38	\$ 12.61	\$ 43.05	
Wood arm, Deadend Dbl	\$ 223.62	\$ 2.88	\$ 3.87	\$ 734.51	\$ 5.19	\$ 6.98	\$ 9.38	\$ 12.61	\$ 999.04	\$ 662.69
Labor	\$ 54.71	\$ -	\$ -	\$ 114.55	\$ -	\$ -	\$ -	\$ -	\$ 169.26	
Materials	\$ 103.54	\$ -	\$ -	\$ 479.48	\$ -	\$ -	\$ -	\$ -	\$ 583.02	
Overhead	\$ 63.23	\$ -	\$ -	\$ 132.39	\$ -	\$ -	\$ -	\$ -	\$ 195.62	
Maintenance	\$ 2.14	\$ 2.88	\$ 3.87	\$ 8.09	\$ 5.19	\$ 6.98	\$ 9.38	\$ 12.61	\$ 51.14	

Recommendations

Fiberglass crossarms are an essential component to any system hardening and resiliency program. Benefits include:

- The longevity of fiberglass crossarms, and consistency maintained by the manufacturing process. Fiberglass crossarms are stronger than wood arms of similar dimensions and have superior electrical properties. Their use is now considered a common industry practice.
- Fiberglass arms are stronger and more predictable than their wood counterparts
- Fiberglass arms are easier to install because they are lighter than wood. They are typically delivered with mounting hardware installed and predrilled holes.
- Fiberglass crossarms are cost effective based on the lifecycle cost.

TRC recommends continuing the use of fiberglass crossarms instead of wood crossarms for all new line construction, line rebuild projects and replacement of existing crossarms for maintenance. Crossarm inspection and replacements should also continue to be part of the pole inspection program to identify failing crossarms.

5.2 Vegetation Management

Current Practices

New Hampshire is ranked second in the United States for forest cover, with an estimated 84% timberland, according to the U. S. Department of Agriculture Forest Service.⁷³ Eversource has approximately 12,200 miles of overhead distribution lines in New Hampshire which are subject to vegetation management. Presently, Eversource implements four vegetation management methods: Scheduled Maintenance Trimming (SMT), Enhanced Tree Trimming (ETT), Full width ROW clearing (ROW), and Enhanced Hazard Tree Removal (ETR), which are detailed below.

SMT: Eversource is within the New Hampshire Public Utility Commission's mandate of a 60-month cycle schedule for SMT. Eversource currently follows this trim cycle targeting approximately 2,400 miles per year. Eversource has attempted to reduce the cycle length to 4.5 years by addressing additional mileage when possible. The Eversource Specification for both single phase and three phase construction calls for the following, as shown in Figure 5-20:

- 15 feet of overhead clearance measured vertically from the highest primary conductor.
- 8 feet side clearances measured horizontally outward from the outermost primary conductors.
- 10 feet under clearance measured vertically downward from the lowest primary conductor.
- Selective removal for brush and vine clearance; only the tree brush which is presently at least 16 feet tall within the removal zone should be removed. All vines growing up poles or guy wires should be cut at the ground line and cleared 6 feet up the pole or guy.

⁷³ USDA, Forest Inventory and Analysis Fiscal Year 2016 Business Report. Page 71-72. Table B-11. Land and forest area and FIA annualized implementation status by State and region, FY 2016. (Percentages for states derived by dividing third column by second column.) Data for territories: Page 70: Table B-10. Status of FIA special project areas excluded from annualized inventory. Retrieved January 8, 2019

Figure 5-20. Eversource SMT Specifications

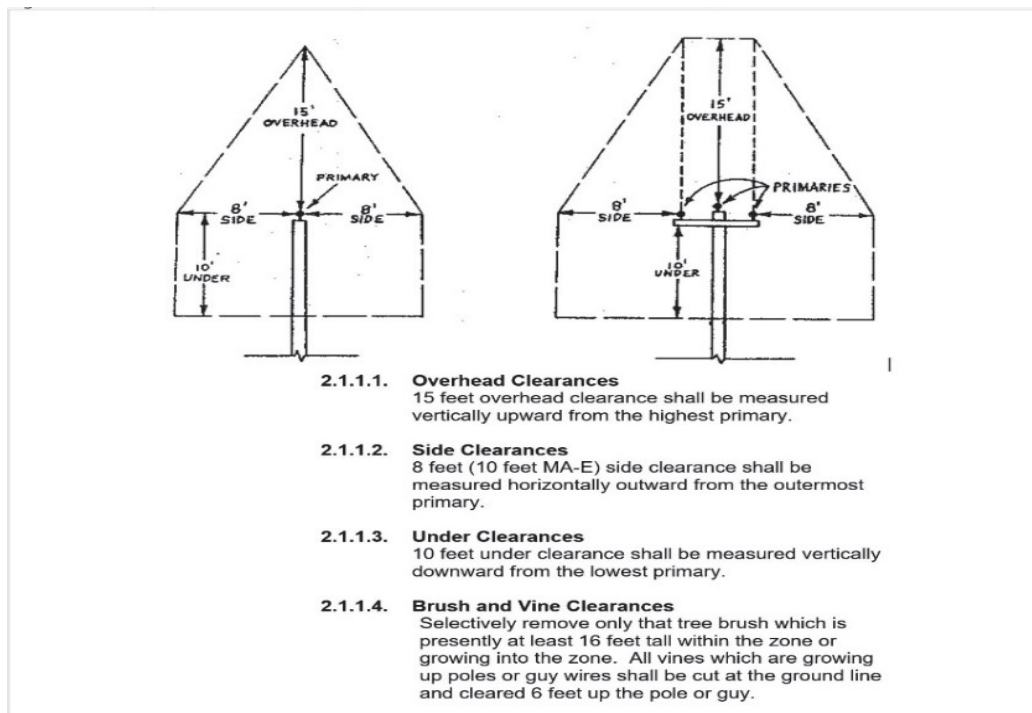

ETT: For 2021, ETT is scheduled to be performed on approximately 50 miles of backbone or mainline circuits and on some poorer performing circuits selected from Eversource reliability data and other performance factors. In 2020, 49 miles were addressed. The average mileage over between 2014 and 2020 was approximately 80 miles annually. To date, approximately 1,100 miles of the 1,600 miles of backbone mainline have been completed. The ETT specifications call for 8 feet side clearances, measured horizontally outward from the outermost primary conductor to either side of the utility poles and primary conductor from the ground up. This includes removal of:

- All overhanging limbs. If overhanging limbs cannot be 100% removed, the tree should be considered for removal. If greater than 1/3 of the tree is to be trimmed to meet the overhang requirement, then the entire tree is to be removed.
- All brush and all trees within the clearance zone.
- All vegetation 10 feet around poles and guying systems.

Additionally, specifications state that:

- Consent forms and details about tree work will be delivered to each property owner in advance of any work performed. Property owner consent is required in writing. Any refusal will be documented and submitted to Eversource weekly.
- Arborist will field verify the completed work.

ETT is only performed on a backbone portion of a circuit one time. Future vegetation management is performed with SMT.

Figure 5-21. Eversource ETT Specifications

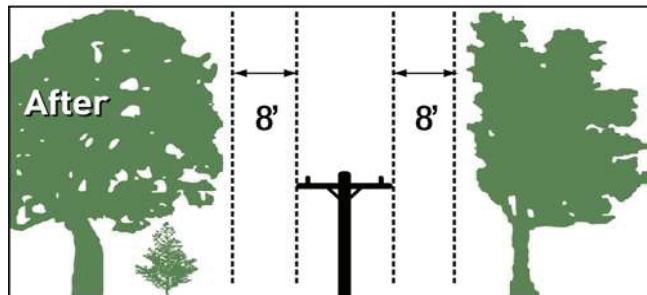

Full-Width ROW Clearing: ROW clearing allows an easement that has been encroached upon with vegetation to be fully cleared and restored to the full easement width from when the line was originally constructed. Once restored, future vegetation management will be performed with SMT.

ETR: ETR involves the identification, and complete removal of trees determined to be a reliability impact to the distribution lines, both within and outside standard trimming zones. During the SMT cycle,⁷⁴ trees are identified that may fail or are a threat to electrical facilities or public safety. These trees are inspected by arborists in the fall zone (i.e., the area outside of the roadside clearance zone where an uprooted tree could strike the conductor and cause an outage).

Trees identified for removal in the fall zone will be approved by the property owner or their representative prior to removal. If consent is denied, the tree will remain as a hazard.

The following contingencies are considered:

- If greater than 1/3 of the tree is to be trimmed via SMT, ETT, or ROW clearing, the tree should be removed as an in-zone removal.
- If a tree is not a hazard at present, but a customer wants it removed regardless, the tree should be removed after being approved by the Owner's Representative. Tree species and form, future maintenance costs, and aesthetics should be considered.

The Company's SMEs indicated that the majority of their customers live among trees. When SMT is performed, hazard trees are identified on three-phase lines and in heavy customer areas; the entire 3-phase line is looked at during SMT. A list of hazard trees is provided to the arborists, who then evaluate the trees to make the determination of which to remove. Once identified, the hazard trees are generally removed within several weeks.

⁷⁴ Since hazard trees are identified during the SMT cycle, Eversource is not likely to revisit a circuit for four to five years.

Industry and Utility Findings

Vegetation management is performed in accordance with the Vegetation Management Document Number 5.60, Rev 2, which states, “Work is performed in compliance with OSHA 1910.269 and ANSI Z133.1 safety standards, ANSI A300 Pruning Standards, International Society of Arboriculture Best Management Practices for Utility Pruning and Eversource’s Specification for Distribution Line Clearance Tree and Brush Work.” The document further states “Property owner consent for tree pruning or removal is required along public roads and on private property.”

Hazard tree removal follows the guide from The International Society of Arboriculture (ISA)’s Handbook of Hazard Tree Evaluation for Utility Arborists. Hazard trees in the fall zone are evaluated based on soil type, depth, drainage and wind susceptibility, tree growth, species, form, insect infestation and tree defects such as: cavities, nesting holes, decay conks, old wounds, 'V' crotches, poor rooting, and poor basal flare.

An article from the Transmission & Distribution World publication in June 2012⁷⁵ references the ANSI standard A300 (Part 9) for Tree Risk Assessment. The article states:

“Utility vegetation management programs have traditionally focused on preventing tree-line contact by obtaining specified clearances. While such programs certainly reduce tree-line contact and prevent some interruptions, many outages are caused by tree and branch failures that originate from outside the specified [vegetation management] scope of work. To improve system performance, utilities are increasingly focusing resources on hazard tree abatement, or, more accurately, tree risk management. Utilities can increase the value of their vegetation management investment by systematically concentrating on trees that pose the highest level of risk. Completely mitigating the risk posed by trees would require utilities to specify pruning or removing any tree with the potential to strike a utility line. Of course, this would be cost prohibitive and raise customer acceptance concerns. More importantly, it would be quite unnecessary since many trees in close proximity to utility lines pose relatively low risk. The key to improving the effectiveness of vegetation management efforts is for utilities to determine the relative level of risk posed, allocate resources to benefit the greatest number of customers, and establish written specifications that clearly define the scope of work for contracted personnel.”

⁷⁵ Transmission & Distribution World, “ANSI Standard Helps Utilities,” June 2012.
<https://www.tdworld.com/vegetation-management/article/20963624/ansi-standard-helps-utilities-manage-risk>

Business Case

One study conducted by Eversource in Connecticut, and summarized in the Journal of Environmental Management, evaluated and compared outage rates for tree related causes on backbone and lateral conductors that received ETT and lateral conductors that had not received ETT to evaluate the effectiveness of ETT on reducing tree related power outages during storm events.⁷⁶ The study, which covered the Eversource system across the entire state of Connecticut for the period 2005-2007,⁷⁷ found ETT-treated conductors had storm outage rates that ranged from 35-180% lower than the service-area's average annual outage rate for untreated conductors. Further, it found a “35-45% reduction in annual storm-related outage rates for backbone lines in storm-damaged areas, when compared to untreated laterals lines: this result is consistent with Eversource’s internal performance review which attributed a 35-40% reduction in outage rates to ETT for backbone lines during major storms.”⁷⁸ Additionally, the study provided empirical information to support the claim that ETT treatment has an impact on reducing power outage rates during storm conditions and referenced other industry reports that supported this claim.

Lastly, the study referenced a report that found “hazardous tree removal and “storm proof” trimming reduced outage rates by 20–30% for an electric utility in Massachusetts.”⁷⁹ The findings of this study and the others referenced clearly support ETT as an effective practice to reduce outages caused by trees, particularly during storm events.

Reliability

There are two reliability measurements that are most impacted by vegetation management: The System Average Interruption Frequency Index (SAIFI) and the System Average Interruption Duration Index (SAIDI).

SAIFI: SAIFI is the average number of sustained interruptions per consumer during the year. It is the ratio of the annual number of interruptions to the total number of customers served. Figure 5-22 shows overall SAIFI by various outage cause categories between 2011 and 2020 in Eversource’s New Hampshire territory. It is evident that tree related outages have been the leading cause of outage events during this time.

⁷⁶ From Journal of Environmental Management 241 (2019) 397–406 Research article “An analysis of enhanced tree trimming effectiveness on reducing power outages”.

Jason R. Parent*, Thomas H. Meyer, John C. Volin, Robert T. Fahey, Chandi Witharana P398

⁷⁷ The variations for weather, tree cover, and wire type were controlled by pairing ETT-treated zones with nearby untreated zones.

⁷⁸ Journal of Environmental Management. “An analysis of enhanced tree trimming effectiveness on reducing power outages.”

⁷⁹ Journal of Environmental Management. “An analysis of enhanced tree trimming effectiveness on reducing power outages.”

Figure 5-22. SAIFI By Causal Category

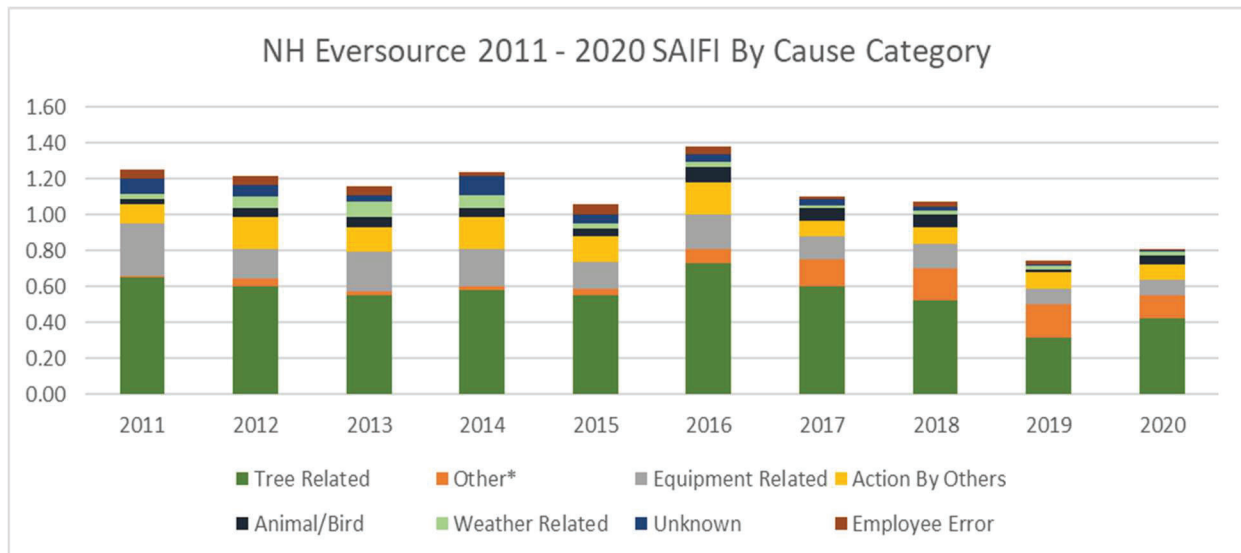

SAIFI is a common measure for tree related performance since it is impact-based rather than time-based. Reduction in SAIFI better reflects a reduction in the number of outage events.

SMT, ETT, and ROW typically affect Trees Inside Zone events. ETR involves the removal of trees both within and outside standard trimming zones and therefore affects both Trees Inside Zone and Trees Outside Zone caused outage events. Since 2011, there has been a significant reduction in SAIFI related to tree inside zone outages due to SMT, ETT and ROW as seen in Figure 5-23.

Figure 5-23. SAIFI for Tree Inside Zone Caused Outages

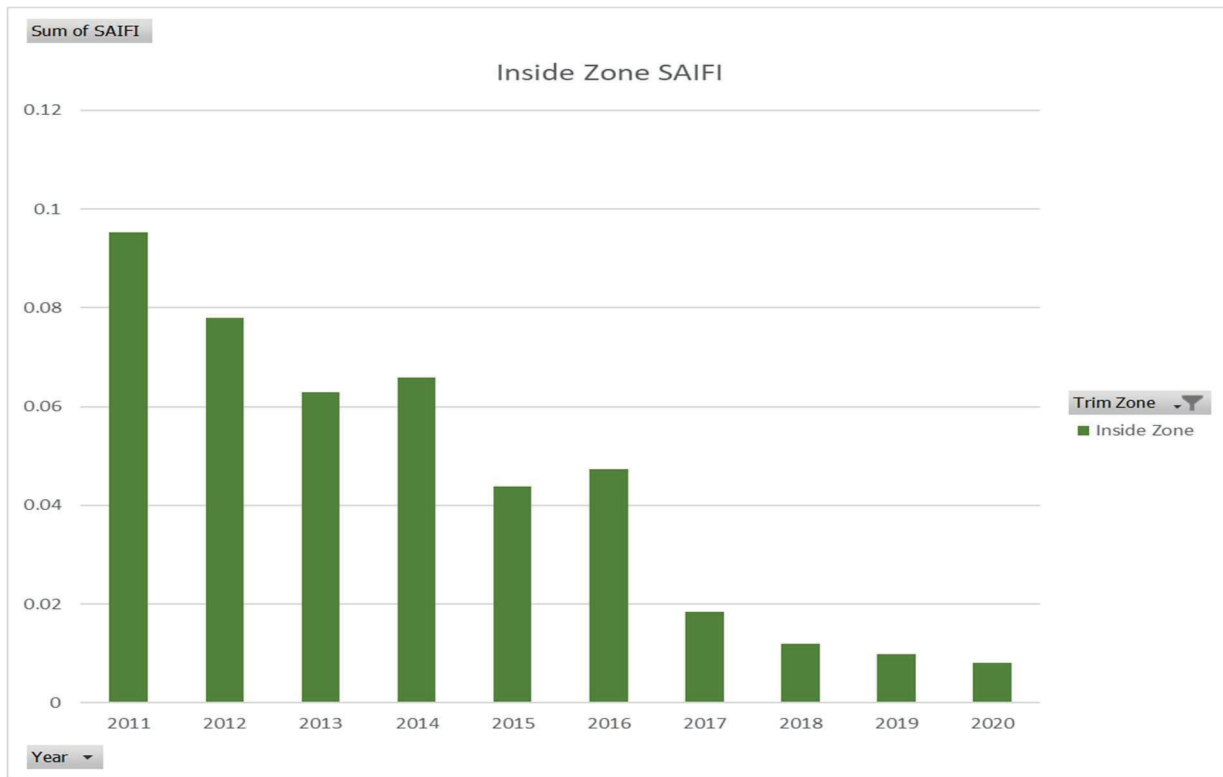

The eventual leveling off for SAIFI, as shown in the above figure, is expected as the zone around the primary lines are cleared and maintained. Since ETT and ROW are typically applied one time on a given distribution line as described previously, it becomes necessary to continue the current SMT program to maintain that level of SAIFI for tree inside zone caused outages.

Figure 5-24 shows vegetation growth on a single-phase distribution transformer pole that SMT will remove.

Figure 5-24. Vegetation on Distribution Transformer Pole



Source: TRC Field Inspections

Since 2016, there has been a downward trend in SAIFI related to tree outside zone outages as seen in Figure 5-25. The Company has direct control over the trees inside the zone due to their right to clear vegetation in the easements. For trees outside the zone, two challenges exist:

- It is difficult to identify all the trees which are either a hazard to the line either from branches breaking or trees falling into the line.
- It is not always possible to acquire permission from the property owner, which is required before trees outside the zone can be trimmed or removed.

For these reasons, the SAIFI for trees Outside Zone will not be as low as Inside Zone.

Figure 5-25. SAIFI for Tree Outside Zone Caused Outages

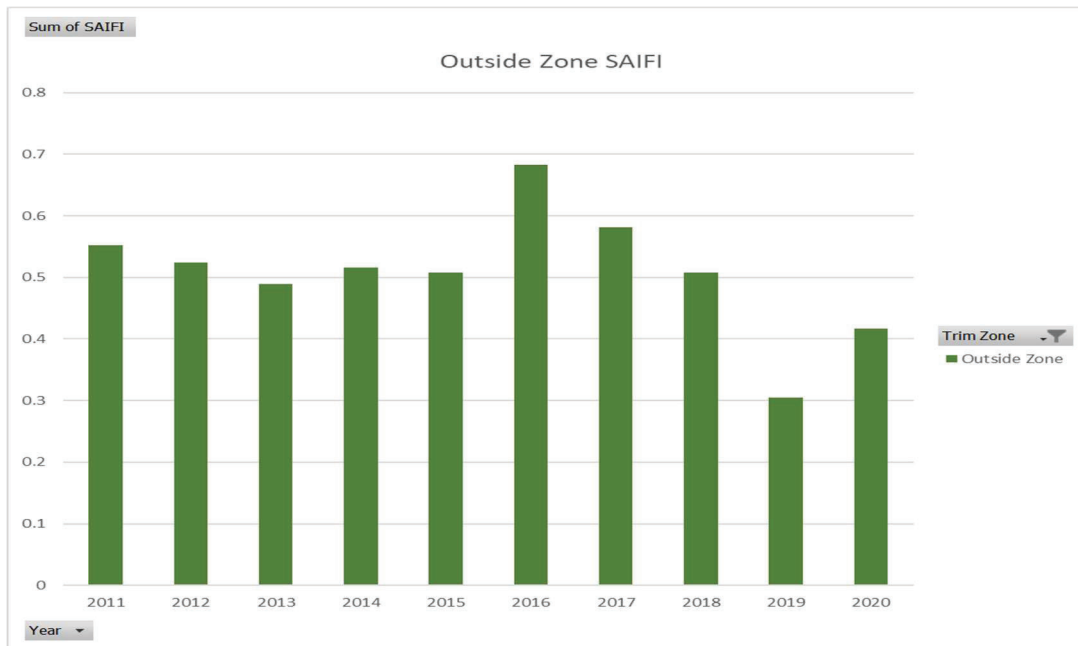

Trees identified by Eversource as ones that may fail and fall into a distribution primary line are removed. However, not all trees that are hazards can be identified. During the time between SMT, trees outside the zone can develop into hazards due to insect infestation, decay or other factors and cause outages.

TRC conducted visual site inspections of distribution circuits located both along roadsides and off-road in ROW. In these locations, vegetation management had been completed via SMT or ETT, with ROW clear. However, it was evident in a number of locations that there were a significant number of trees outside the zone that were more than two times the height of the distribution line. An undetected hazard tree that fails and falls toward the line would likely damage the primary and or poles. Due to the sample number of locations observed and the amount of vegetation existing outside the easement, it is unlikely that the amount of Tree Outside Zone caused outages would continue to reduce in the same manner the Trees Inside Zone metric has in recent years.

Figure 5-26 and Figure 5-27 show a portion of circuits that have been cleared with trees outside the zone.

Figure 5-26. Trees Outside Zone in Right-of-Way



Source: TRC Field Inspections

Figure 5-27. Trees Outside Zone Along Roadside



Source: TRC Field Inspections

Figure 5-28 and Figure 5-29 show a portion of a circuit before and after ETT and ETR clearing was performed. Trees on the right side are encroaching on the line including several potential hazard trees.

Figure 5-28. Eversource circuit prior to ETT clearing



Source: Eversource

Figure 5-29. Eversource circuit after ETT clearing



Source: Eversource

Figure 5-30 and Figure 5-31 show a distribution line before and after ROW clearing was performed.

Figure 5-30. Eversource circuit prior to ROW clearing



Source: Eversource

Figure 5-31. Eversource Circuit following ROW clearing



Source: Eversource

Figure 5-32 and Figure 5-33 show a before and after ROW clearing was performed to remove trees and vegetation encroaching on the right-of-way and mitigate the potential for tree contact.

Figure 5-32. Eversource circuit prior to ROW clearing



Source: Eversource

Figure 5-33. Eversource circuit after ROW clearing



Source: Eversource

The impacts of the extended times between trim cycles or reducing the annual miles to be trimmed may have a significant negative effect on reliability. One study conducted to evaluate the impact of deferring vegetation clearing on distribution lines found that the cost to clear the line after one year of deferral required a significant increase in labor and cost to bring the line clearance in line with specifications.⁸⁰ The study was conducted on three electric utility properties in the U.S. by Environmental Consultants, Inc. Field data was collected and used in a predictive model looking at labor requirements, cost impacts and biomass disposal resulting from deferred maintenance. As shown in Figure 5-34, labor time and cost both increase when SMT is deferred. The study also projected that biomass (chipped debris) could double with one year of trimming deferral which would increase the cost for removal.

⁸⁰ The Economic Impacts of Deferring Electric Utility Tree Maintenance, by D. Mark Browning and Harry V. Wiant, from Journal of Arboriculture 23(3): May 1997. pp 106 – 111. https://www.eci-consulting.com/wp-content/uploads/2017/10/Deferring-Electric-Utility-Tree-Maintenance_JOA.pdf

Figure 5-34. Impact of Deferring SMT

Number of Years Trimming is Deferred	Average Labor Time Increase	Average Relative Cost Increase
1 Year	21%	20%
2 Years	38%	37%
3 Years	52%	51%
4 Years	62%	60%

Source: Journal of Arboriculture

The study also modeled a 20 percent decrease in annual funding for a cycle-based maintenance program. Although it would seem that a 5-year cycle would increase to 6.25 years with a 20 percent decrease in annual funding, in reality, the cycle is extended much longer – to 9 years, due to the additional years’ growth beyond what would have to be managed in a 5-year cycle. This study did not account for the impact on the deferred trimming on reliability or the additional off cycle maintenance costs.

SAIDI: SAIDI is the average duration of interruptions per customer during the year, measured in minutes. It is the ratio of the annual duration of sustained interruptions to the total number of customers served.

An NHPUC Utility Analyst notes that while SAIDI is an appropriate second level decision tool for tree-based reliability enhancements, care should be taken to ensure inputs are uniform:⁸¹

“...unless the resource and geographic parameters are uniform, the SAIDI data can inflate or reduce a circuits tree performance. This is due to crew response which can be largely dictated by time of day, day of the week, number of crews that are on the property that day, or if there are concurrent outages occurring at the same time. The same location may experience different crew restoration times and therefore change the SAIDI of the tree related event month to month or year to year.”

There has been a significant reduction in SAIDI related to tree inside zone outages since 2011 as seen in Figure 5-35 and a slight downward trend in SAIDI related to tree outside zone outages since 2016 as shown in Figure 5-36.

⁸¹ Direct Testimony Kurt Demmer, Utility Analyst NHPUC, December 20, 2019, page 21.

Figure 5-35. SAIDI for Tree Inside Zone Caused Outages

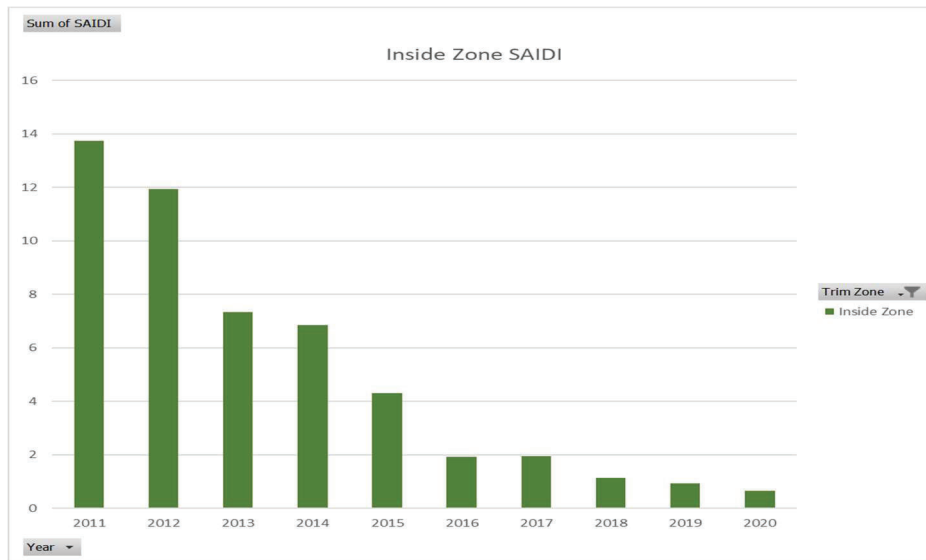
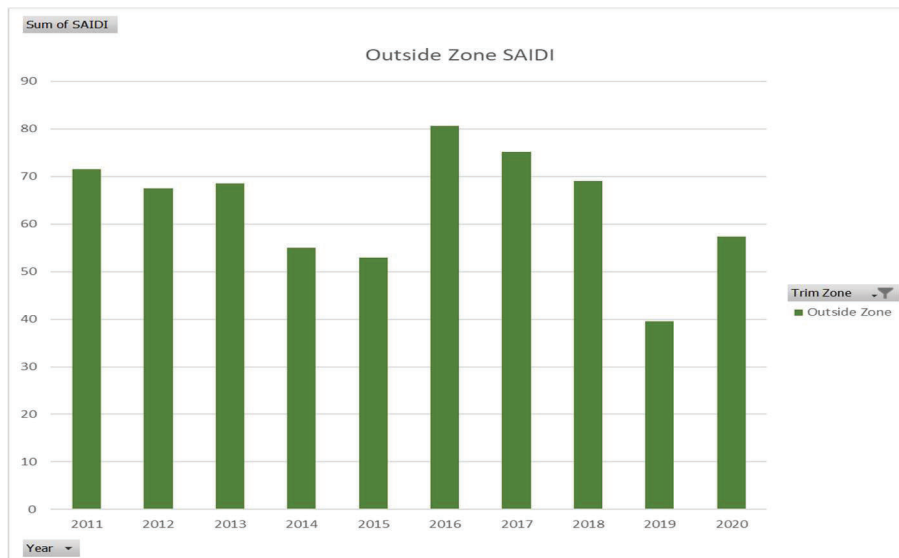

Figure 5-36. SAIDI for Tree Outside Zone Caused Outages



The SMT, ETT and ROW programs have addressed Inside Zone trees, resulting in significantly fewer outages. Outages from Outside Zone trees tend to result in more severe damage from trees falling into the line, which can increase in the amount of time spent on service restoration. Although service restoration is not a vegetation management expense, it is an operational expense that can be directly related to vegetation conditions and should therefore be considered.

Cost Analysis

Eversource has budgeted \$27.1M for vegetation management in 2021, more than half of which is designated for SMT.⁸² The breakout of activities is shown below in Figure 5-376.

Figure 5-37. Eversource 2021 Vegetation Management Portfolio Budget

Vegetation Management Activity	2021 Budget (\$M)
SMT	\$14.0
ETT & ETR	\$11.6
ROW	\$1.5

Source: Eversource Direct Testimony

As noted in Figure 5-23 and Figure 5-35, both SAIFI and SAIDI for Inside Zone tree-caused outages have shown reductions over the last decade and appear to have leveled off. SMT will now be an ongoing program that will mitigate mostly Tree Inside Zone caused outages. To maintain the current level of reliability with SMT and comply with New Hampshire Public Utility Commission’s mandate of a 60-month cycle schedule, the Company would need to maintain an average of 2,440 miles annually, or 20% of the system.

Eversource’s current vegetation management contract for SMT covers the 4-year period from January 1, 2021 through December 31, 2024. The estimated cost for SMT in 2021 is approximately \$7,000 per mile, which is up from \$6,000 per mile in 2020 and from \$5,235 per mile between 2016 and 2018.⁸³ The increase is attributed to market conditions, as contractors have been challenged with the availability of skilled and experienced tree resource labor and an increase in areas expecting more significant traffic control, such as a police detail instead of flaggers. The cost increases will likely continue through the remainder of the current contract due to these prevailing conditions. Based on the current \$7,000 per mile, Eversource would require \$17.1 million, more than \$3 million more than budgeted, to complete SMT for the average 2,440 miles annually. This gap will continue to widen if per mile costs increase over the contract period.

At current per-mile costs and the present funding level of \$14.0 million, Eversource would be able to maintain approximately 2,000 miles in 2021, approximately 82% of the amount required under the 60-month schedule. Figure 5-38 illustrates the impact of deferring SMT in additional cost and labor. A one-year deferral in SMT would increase the cost from \$7,000 to \$8,400 per mile deferred. Sustaining the 2021 budget level of \$14 million for SMT would lead to increasing deferrals and escalating average costs per mile. As shown in Figure 5-387, by 2024, almost all of Eversource’s SMT activities would be addressing miles that were deferred in the previous year – at a higher cost per mile. By 2025, some miles would begin to be deferred by two years,

⁸² Public Service Company of New Hampshire, Direct Testimony of Joseph A. Purington and Lee G. Lajoie - Grid Transformation and Enablement Program: Acceleration of Targeted Infrastructure Upgrades, Docket DE 19-057, 5/28/2019. https://www.puc.nh.gov/regulatory/Docketbk/2019/19-057/INITIAL%20FILING%20-%20PETITION/19-057_2019-05-28_EVERSOURCE_DTESTIMONY_PURINGTON_LAJOIE.PDF

⁸³ New Hampshire Public Utilities Commission, Direct Testimony of Kurt Demmer, Docket DE 19-057 December 20, 2019

further increasing costs-per-mile (to nearly \$9,600), and this spiraling of average costs would continue until investment levels are increased to return to a five-year schedule or market conditions changed to reduce costs for vegetation management resources.

Figure 5-38. Cost increases resulting from under-investment in vegetation management

	2021	2022	2023	2024
Budget	\$14,000,000	\$14,000,000	\$14,000,000	\$14,000,000
Base cost-per-mile	\$7,000	\$7,000	\$7,000	\$7,000
Deferred cost per mile (1 year)		\$8,400	\$8,400	\$8,400
Previous year deferred miles		440	968	1,602
Budget used to address deferral		\$3,696,000	\$8,131,200	\$13,453,440
Remaining budget for base SMT		\$10,304,000	\$5,868,800	\$546,560
Base miles maintained	2,000	1,472	838	78
Average Cost per Mile	\$7,000	\$7,322	\$7,750	\$8,335

Notably, the modeling above is conservative in that it does not reflect expected cost increases per mile as described above due to market conditions; if these were factored in, the trends would be further exacerbated. The increasing rate of deferred miles modeled above would lead to a regression in the reliability metric improvements noted above. In total, Eversource would see both increasing costs per mile and decreasing reliability benefits at the same time if this underinvestment in SMT persists. As a result, TRC recommends the SMT budget be increased to \$17.1 million for 2021 to maintain the 5-year maintenance schedule. Future year budgets should be adjusted as necessary to account for increasing labor resource costs.

Since SMT targets Tree Inside Zone-caused outages, ETT, ETR and ROW will primarily address the Tree Outside Zone caused outages. The 2021 budget for these programs is \$13.1 million. During the past 5 years, the average ETT spend was \$5.1 million, ETR was \$10.2, and combined ETT/ETR spend \$15.3 million. If a portion of this budget were repurposed to address the shortfall in SMT described above, TRC expects that the progress in Tree Outside-Zone caused outages would be reversed as fewer resources are available to address these hazards.

TRC analyzed overall vegetation management costs and benefits using the Department of Energy's Interruption Cost Estimate (ICE) Calculator.⁸⁴ This tool was designed for electric utility reliability planners, government organizations or other entities to help estimate interruption costs and/or the benefits associated with reliability improvements in the United States. Looking at the SAIFI and SAIDI improvements for Tree-caused outages between 2011 and 2020, the tool shows a reliability benefit per customer of \$335 over a ten-year period. See Figure 5-39 below.

⁸⁴ U.S. Department of Energy Office of Electricity, Interruption Cost Estimate (ICE) Calculator, accessed 5/3/21. <https://www.icecalculator.com/home>

Figure 5-39. ICE Calculator Value of Reliability Improvement for Eversource 2011-2020 Vegetation Management

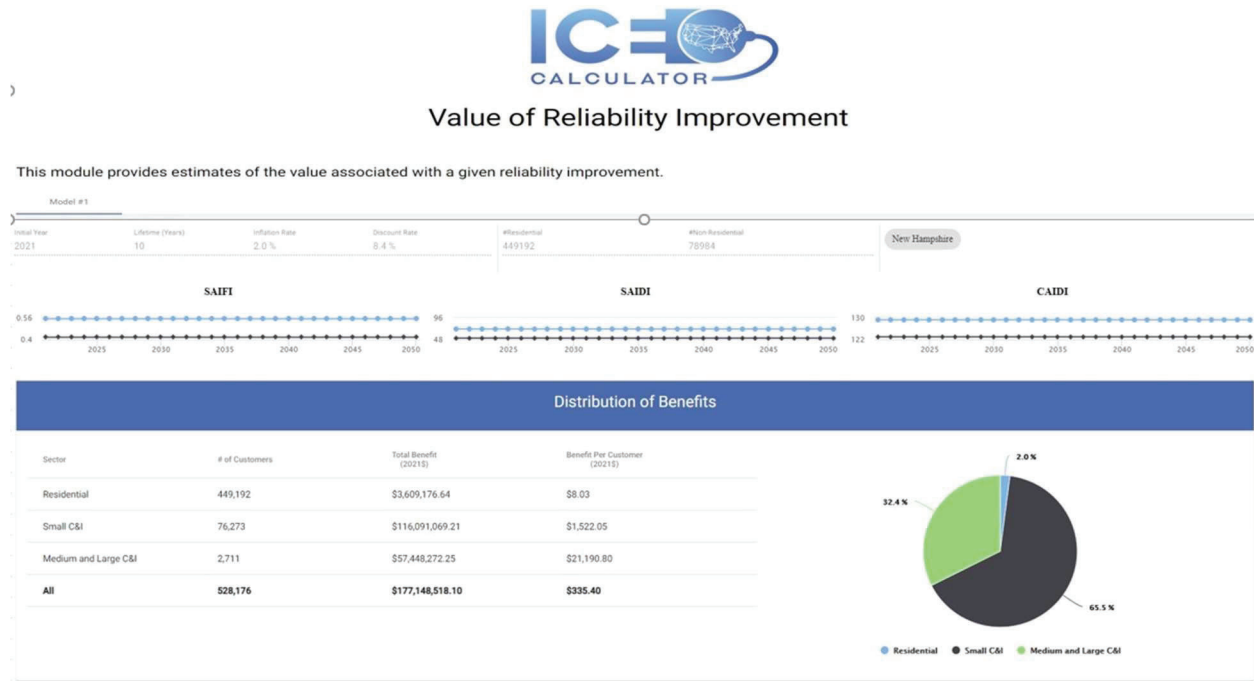

Source: U.S. DOE ICE Calculator

On an annual basis, this reliability benefit equates to \$33.50 per customer. Based on the current level of spend for the non-SMT vegetation management of \$13.1 million, the annual average cost per customer is \$24.77, which results in a net benefit of nearly \$9 per customer. The annual average benefit of \$33.50 would support an increased budget of up to approximately \$17.7 million annually for the combined ETT, ETR and ROW programs, before costs would outweigh these customer benefits.

ETT has averaged over 80 miles of backbone circuit per year between 2014 and 2020. The target is 50 miles in 2021.

TRC performed a second, more targeted cost effectiveness analysis for ETT using 11 circuits which had most, if not all the backbone trimmed to ETT specifications. In this analysis, TRC compared the circuit reliability for SAIFI and Customer Average Interruption Duration Index (CAIDI) for the years 2011 through the year ETT was completed against the metrics for years after ETT was conducted. There was an observed 58% decrease in SAIFI between the pre- and post-ETT years and a decrease of 5% in CAIDI of 5% for these circuits following the ETT clearing, as seen in Figure 5-40 and Figure 5-41.

Figure 5-40. Pre- and Post-ETT SAIFI for 11 Analyzed

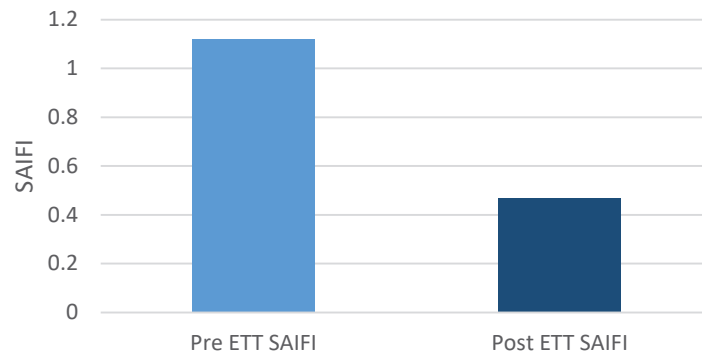
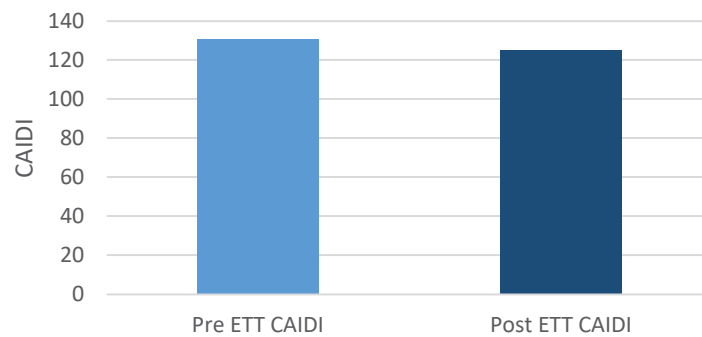
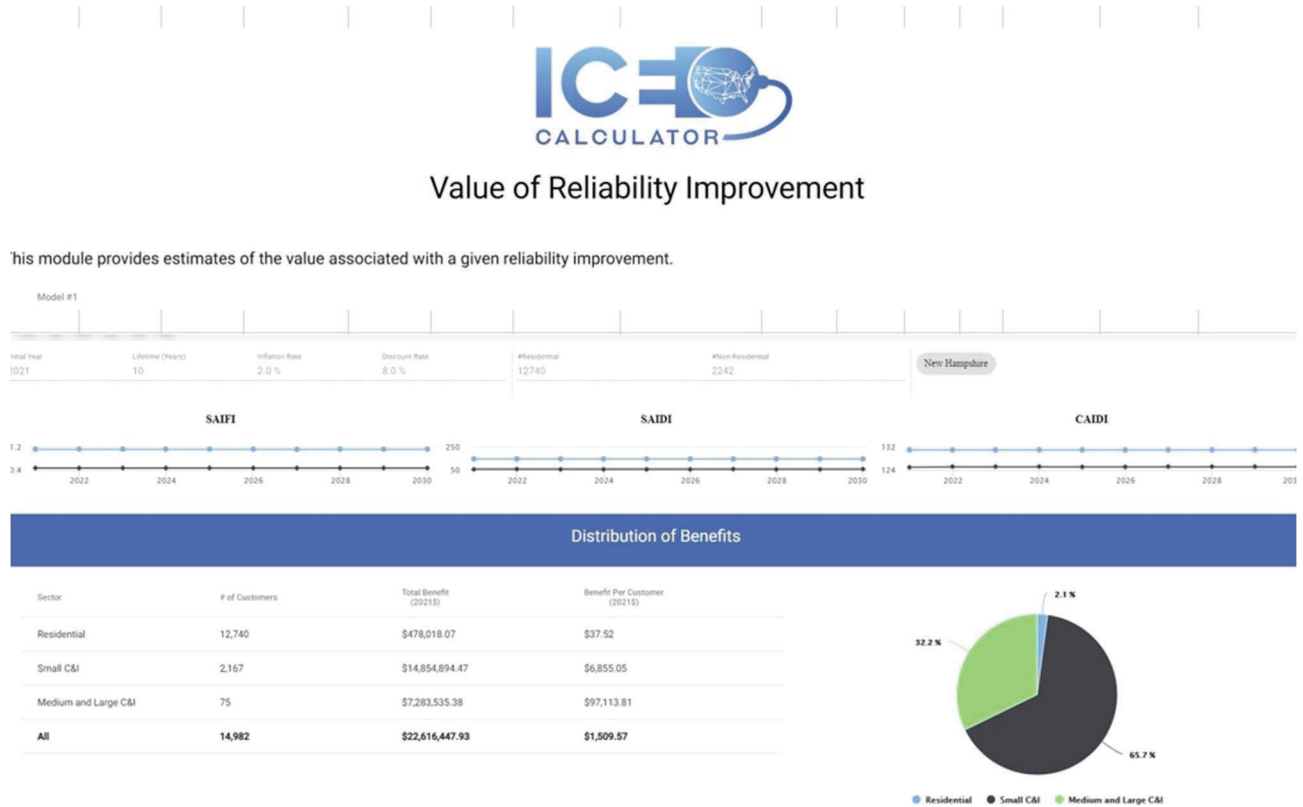

Figure 5-41. Pre- and Post-ETT CAIDI for 11 Analyzed Circuits



This group of circuits shows improvement in reliability when comparing reliability before ETT and after ETT was performed. This information was then applied in the Interruption Cost Estimate (ICE) Calculator tool focusing at the SAIFI and CAIDI improvements for Tree caused outages between 2011 and 2019, as shown in Figure 5-42.

Figure 5-42. ICE Calculator Value of Reliability Improvement for Eversource 2011-2020 Vegetation Management – Pre- and Post-ETT on 11 Circuits



Source: U.S. DOE ICE Calculator

The tool shows a reliability benefit per customer of \$1,510 over a ten-year period. This is the benefit gained for these entire circuits where ETT has been performed on the backbone. Using the total mileage of ETT performed on these 11 circuits, average costs per year when they were performed, and number of customers served by each circuit, the average cost per customer for these ETT activities was \$371, significantly less than the total reliability benefit per customer of \$1,510. Based on these findings, we conclude the ETT activities to be highly cost effective for the value of reliability benefits according to the ICE calculator.

During the past 3 years, ETR has been performed under unit pricing. The cost per removal was based on the negotiated amount by tree diameter size. Between 2018 and 2020, an average of 18,900 trees were removed annually at an average cost of \$680 each.

Recommendations

Based on the cost-effectiveness findings of the ICE calculator tool, TRC recommends continuing with Scheduled Maintenance Trimming (SMT), Enhanced Tree Trimming (ETT), Full width ROW clearing (ROW), and Enhanced Hazard Tree Removal (ETR), and funding these efforts to avoid incurring escalating costs from deferred maintenance. TRC recommends the following:

- **SMT:** Address an average 2,440 miles annually to follow the 60-month clearing cycle. This will focus on the Inside Zone vegetation and maintain the level of tree caused outages at current levels as indicated by Figure 5-23. Deferral of this work for a year or more will risk erasing the progress on tree-related reliability improvements achieved over the last decade and lead to increasing costs per mile and physical resource needs. This will likely have an impact on the budget. Based on the Company's estimate of \$7,000 per mile for 2021, it would cost \$17.1 million to complete SMT for this year. Budget adjustments may be necessary in subsequent years to maintain this pace.
- **ETT:** Accelerate ETT to 80 miles per year to address the remaining 500 miles of the backbone circuits within the next seven years. This will likely have an impact on the budget and be subject to availability of physical resources.
- **ROW:** Continue clearing at the current pace to allow for the restoration of the full original easement where vegetation has encroached.
- **ETR:** Target approximately 19,000 hazard tree removals annually following the current identification and prioritization practice. The cost for this will be subject to the size of the trees removed. Evaluate additional strategies to drive improvements in outside-zone tree-related outage performance.

5.3 Substation Transformers

Current Practices

Eversource Distribution System Planning Guide defines the design criteria for the sizing of a distribution power transformer. Any facility that operates at a voltage of 100kV or higher is considered part of the Bulk Electric System (BES).⁸⁵ The loading of bulk transformers under normal operation (N-0) system conditions are not to exceed 95% of the normal rating. Any loading beyond this will increase the risk of equipment failure and reduce customer reliability when exposed to a single contingency operation (N-1). The loading of non-bulk transformers varies slightly from that of bulk transformers. Non-bulk transformers planned loading shall not exceed 100% of the normal rating under (N-0) system conditions. Under (N-1) conditions for non-bulk transformers, the loading of the transformer is to be reduced below the long-term emergency (LTE) rating.

The criteria above are set to provide proper pre-loading conditions to allow the transformers to operate effectively below LTE, short-term emergency (STE), and drastic action limit (DAL) ratings. The condition rating percentages do not restrict the actual operation of the transformer. All transmission owners in New England are required to provide their own set ratings and duration times for these categories per ISO-NE PP-7 section 2.3⁸⁶. These include durations for both summer and winter loading. Eversource utilizes the following durations for contingency

⁸⁵ NERC. *NERC Review of Bulk Electric System Definition Thresholds*. Mar. 2013, www.nerc.com/pa/Stand/Project%20201017%20Proposed%20Definition%20of%20Bulk%20Electri/bes_p_hase2_pc_report_final_20130306.pdf.

⁸⁶ ISO NEW ENGLAND PLANNING PROCEDURE NO.7. ISO New England, 7 Nov. 2014, www.iso-ne.com/static-assets/documents/rules_proceeds/isone_plan/pp07/pp7_final.pdf.

analysis:

- Normal Ratings – Continuous
- Winter LTE (W LTE) – 4 hours
- Summer LTE (S LTE) – 12 hours
- Winter STE (W STE) – 30 minutes
- Summer STE (S STE) – 30 minutes
- Drastic Action Limits (DAL) - Equal to the STE for summer and winter ratings

To maximize the substation output, Eversource bulk distribution stations are designed to consider the loss of the largest distribution element during an (N-1) contingency, in addition to the load that can be transferred out of the station post contingency. Dispatcher initiated load transfers are to be available to keep transformer winding loads below the LTE rating within the set time frame detailed below:

- The initial post-event assessment period for dispatchers to identify/assess the event shall be 10 minutes.
- The time to implement each load transfer is 5 minutes.
- All load transfers are sequential, when more than one is needed:
 - Two transfers take 10 minutes.
 - Three transfers take 15 minutes.
- Where possible, there should be at least one extra load transfer available if one of the primary load transfers cannot be accomplished.

Following the loss of a non-bulk transformer, if distribution switching cannot restore customers within 24 hours, it will be required to position a mobile substation to restore service. For restoration of a bulk transformer, restoration capacity is required within the distribution system to ensure no loss of service. Eversource is required to perform annual tests and regularly schedule maintenance in accordance with Eversource Maintenance plan chapters 5.58 and 6.58 to maintain reliability.

Typical Usage and Installation Practices

Eversource is required to make transformer and substation upgrades to mitigate any risks to capacity, power quality, and reliability. Various strategic criteria are assessed when deciding to make substation upgrades. The upgrades to bulk distribution substations are based on the following order when addressing criteria violations:

- 1) Highest to lowest overloads under normal (N-0) and (N-1) contingency conditions.
- 2) Load loss under first contingency (N-1) conditions.
- 3) Highest to lowest number of customers impacted during contingency conditions.
 - a) Associated risk evaluation of substation based on individual components (Asset condition). The asset condition criteria do not include equipment with asset

conditions deemed a safety hazard, those should be prioritized and resolved under emergency conditions.

These steps help prioritize reliability driven replacements to provide reduced outage time to those that may be affected by power outages. Individual substations are then assessed by distribution system planning for violations and then ranked based on Figure 5-43 below.

Figure 5-43. System Violation Ranking

Priority Number	Violation Type	Description
1.	Capacity	Bulk Distribution Substation Overloads
2.	Capacity	Non-Bulk Distribution Substation Overload
3.	Reliability	Single Contingency (N-1) load loss
4.	Reliability Power Quality	Substations with higher risk of equipment failure, due to asset condition or power quality violations, supplying High Load Density Areas
5.	Reliability Power Quality	Substations with higher risk of equipment failure, due to asset condition or power quality violations, supplying Low Load Density Areas
6.	Power Quality	Power quality Violations such as Harmonics, TOV, ROI
7.	Reliability	Non-Standard Substation Design

Source: Section 2.9 of the Eversource Distribution System Planning Guide

Once a distribution transformer is identified for replacement at a substation, the sizing of that transformer is based on the respective substation voltage class. Figure 5-44 shows Eversource transformer sizes based on recent completed projects and proposed future upgrades.

Figure 5-44. Eversource Bulk Transformer Sizing

Substation Voltage (kV)	Transformer Size (MVA)
34.5	62.5
12.48	30
4.16	10

Source: Eversource interviews

Figure 5-45. New 62.5 MVA Transformer at Pemigewasset Substation



Source: TRC Field Inspections

Per Eversource interviews, the standard high side point of disconnect for a station power transformer is currently a circuit switcher. The amperage rating of the circuit switcher is based on the size of the transformer. The key driver for the addition of a new circuit switcher would be to increase reliability from stations that rely on disconnect switches as the point of disconnect on the high side of the transformer. A circuit switcher would also need to be replaced to support a transformer addition if the current circuit switcher is not rated properly for the increase in size. If the fault current is too large, the circuit switcher would be unable to trip, leading to reliance on remote breakers and slowing the switching scheme. Eversource typically interrupts faults on the low side of the transformer, which is why circuit switchers are the current installation standard. The addition of a vacuum circuit breaker on the high side of the transformer provides more reliability for transformer differential currents and over-current protection than a circuit switcher.

Feeder breakers within distribution yards are used to provide protection for incoming feeder lines. The typical standard breakers used for new feeder installs are 1200-amp outdoor circuit breakers. A breaker replacement is typically triggered by the age of the breaker; there is no set number of years that will trigger a replacement, but age is the main factor that determines what breakers to replace. Equipment failure can lead to replacements as well. If a certain breaker is experiencing repeated maintenance over time, this could trigger a breaker replacement project.

Industry and Other Utility Findings

Changes in electricity usage and risks to the electric grid across the country are driving new investments in substations to build a more resilient electric system at these critical nodes. The US Energy Information Administration projects electricity usage will continue to grow at approximately 1% per year through 2050.⁸⁷ In addition to severe weather, these risks include cyber threats, physical threats, an increasingly renewable and intermittent generation portfolio, and the growing interdependencies of natural gas and water usage. The insufficient integration of natural gas and water into the electric grid opens the door to threats such as vulnerability to cyber threats and severe weather. Utilities and the U.S. Department of Energy are pushing for transformer upgrades across the grid to increase customer resiliency.⁸⁸

One program designed to address challenges associated with power transformers is the Transformer Resilience and Advanced Components (TRAC) program,⁸⁹ which promotes transformer upgrades. This program supports the research and development (R&D) activities to advance technologies and approaches that maximize the value and lifetimes of existing grid components. The goal is to accelerate grid modernization by addressing deficiencies of large power transformers, Solid State Power Substations, and other critical grid hardware components. Also, to increase the resilience of aging assets and identify new requirements for future grid components.⁹⁰ The program has increased its scope and funding since 2016 to pinpoint the industry's critical application needs and technology challenges.

Other Utilities within the Northeast are focusing on transformer upgrades to increase resiliency as well. These utilities are focusing on standardizing their transformers to not only provide a more reliable service, but to increase efficiencies and operational consistency. This leads to more spare power transformers across the system, reduces the amount of maintenance required, and provides access to replacement parts.

Business Case

Eversource's planning criteria calls for restoring service within established criteria, with in-place capacity. To standardize transformer(s) it is important to consider the loss of the largest element during an N-1 contingency condition in addition to the load that can be transferred out of the station post contingency. Firm and Load Carrying Capability (LCC) ratings are used to account for both of these limits. Firm Capacity is defined as the total LTE rating of the remaining transformer(s) after the loss of the largest transformer (refer to Section 6.1 of Guide for full

⁸⁷ U.S. Energy Information Administration, Annual Energy Outlook 2021, February 2021, <https://www.eia.gov/outlooks/aeo/electricity/sub-topic-01.php>

⁸⁸ U.S DOE Office of Electricity, Solid State Power Substation Technology Roadmap, June 2020, www.energy.gov/sites/default/files/2020/07/f76/2020%20Solid%20State%20Power%20Substation%20Technology%20Roadmap.pdf.

⁸⁹ U.S DOE Office of Electricity, Transformer Resilience and Advanced Components (TRAC) Program. www.energy.gov/oe/transformer-resilience-and-advanced-components-trac-program.

⁹⁰ U.S DOE Office of Electricity, 2019 Transformer Resilience and Advanced Components Program Review. <https://www.energy.gov/oe/2019-transformer-resilience-and-advanced-components-program-review>

definition). LCC is defined as the Firm Capacity plus Distribution Transfer Switching Capacity. Distribution Transfer Switching Capacity is calculated by assuming successful transfers of load to other stations is completed within 30 minutes.

The 30-minute STE limit used for Distribution Transfer Capacity is driven by constraints under various operational conditions. The Portsmouth Substation – Second Transformer project serves as an example of these constraints. Here, Eversource determined that additional capacity was needed in the area. To meet the planning criteria, the selected plan called for replacing the existing 44 MVA transformer at Portsmouth station with a 62.5 MVA unit and adding a second 62.5 MVA unit, enabling the planning criteria to be met. An alternative, adding a 62.5 MVA transformer along with the existing 44.8 MVA unit, would not provide adequate capacity to meet the planning criteria under the LTE rating. If the 44.8 MVA transformer was the standard, a third 44.8 MVA transformer would need to be installed. This would likely require additional bus work on the 115 kV source side, additional transformer protection and additional work to integrate the distribution bus work. The differential cost between the 62.5 MVA and 44.8 MVA transformers would be far exceeded by the cost of this additional work.⁹¹ The standard size transformer strategy supports timely load carry or transfer for event-based response, resulting in less dependency on mobile substations. A lesser, but notable benefit is a more consistent and streamlined spare parts inventory.

Cost Analysis

Per Eversource interviews, power transformers are typically custom made, with lead times of up to a year or more to deliver; parts across size and manufacturer are not readily interchangeable. Per Eversource, Hyosung Corporation states it is difficult to compare historical costs of transformers as they vary greatly based on the markets. Standardizing transformer sizing could reduce costs by having a more consistent replacement parts inventory and increase efficiencies through engineering, procurement, installation, maintenance, and testing.

The 115-34.5 kV power transformer is the most common distribution transformer within Eversource NH. It is beneficial to look at the costs of upgrading these from the typical 44.8MVA transformer to the new 62.5 MVA transformer. Per Eversource interviews, it is typically around an 8-10% increase in price to go from a 44.8 MVA transformer to a 62.5 MVA transformer. This would be about an \$85,000-\$110,000 increase in cost. The current pricing for a 62.5 MVA transformer is around \$1.1 million. Standard size transformers are essential to planning guide compliance. The incremental cost of any of the transformers is a small portion of the typical project cost needed to install them.

The Company has decided to right-size new equipment to comply with the established reliability planning criteria, which is an event-based system reconfiguration required to maintain the level

⁹¹ Dispatcher initiated load transfers (using distribution automation capabilities, manual switching is not used for this purpose) must be available to lower transformer winding loads to below the LTE rating, within the time frame given below. When distribution load transfers are used for reducing transformer winding loads to below the LTE rating, following the time frames as described in section 1 (Eversource Practices).

of reliability specified by the Eversource Distribution System Planning Guide. Continued use of smaller transformers would not support the outlined planning criteria and lead to longer outage times.

When looking into the point of isolation on the high side of the transformer, the 115kV circuit switcher and 115kV circuit breaker are to be compared. Per Eversource interviews, a 115kV circuit breaker cost is around \$63,800. The breaker has current transformers which allow for a smaller protection zone, so when attached to the bus it can be wired into different schemes. The cost of a circuit switcher would be around \$112,800. The relay and control wiring cost for the breaker is larger than the differential in material cost between the breaker and circuit switcher. The foundation and steel requirements are similar in comparison. Overall, the total install cost for a circuit breaker is around 10% more than that of the circuit switcher.

Recommendations

Transformer resiliency is a significant issue today which leads to increased outages, outage duration, and loss of service for customers. The criteria for replacing transformers internally within Eversource sets strict guidelines that capture the need to replace transformers under certain criteria and address specific areas of concern.

Networking feeds will decrease the need for mobile substation readiness and relying solely on mobile substations to pick up load. The install and maintenance of mobile stations is a burden among field personnel and maintenance crews. Per Eversource, since a mobile substation consists of a transformer and supporting device to support simplified installation during an event, the typical maintenance of a mobile substation is three weeks as compared to that of a regular transformer of one week. Eversource needs to ensure that all mobile substations are adequately sized and can restore load due to the increase in standard 115-34.5kV transformer sizes.

TRC recommends following Eversource guidelines of standardizing transformer sizes throughout the system based on voltage class. Standardization will lead to more consistency, efficiency, and potentially reducing spare transformer stock and will benefit as follows:

- Standardized replacement parts would result in a more consistent and streamlined parts inventory. This could help reduce event response time, especially if it reduces the need for a mobile substation.
- This will reduce the cost of engineering across standardized vendor drawings. The internal review process of standardized transformers will be more reliable and efficient, reducing the overall procurement cycle.

Any transformer that is removed from service due to a substation improvement project could be redeployed elsewhere on the system where practical. Strategically retain any reliable non-standard sized transformers that was removed from service under the planning guide for future use as an emergency replacement in kind.

TRC recommends continuation of the standard sized transformer implementation strategy.

5.4 Distribution Planning

Eversource Standard Planning Practices:

The Eversource Distribution System Planning Guide (Guide) states that

Distribution Feeder design is intended to provide safe, reliable service within allowed voltage limits at a reasonable cost. Reliability generally addresses interruptions of service for both the number and length of interruption duration. Eversource uses three reliability measures adopted by the utility industry: System Average Interruption Duration Index (SAIDI), System Average Interruption Frequency Index (SAFI), and Customer Average Interruption Duration Index (CAIDI), refer to Distribution System Engineering Manual (DSEM), Reliability Section 02.11. There are limits as to what degree of reliability is practical or achievable, depending on the investment cost and rates permitted by regulatory authorities. To evaluate the effectiveness of reliability projects and determine the most cost-effective solution, Eversource follows DSEM 03.30.⁹²

Eversource utilizes the following solutions to maintain approved regulatory reliability indices where reliability improvements are needed:

- Add automatic sectionalizing devices to limit exposure to 500 customers or less per switchable zone. Refer to DSEM 02.30, DSEM 06.51, and DSEM 10.42.
- Eliminate or reconfigure triple circuit pole lines to minimize customer exposure for single emergency events that result in more than 1000 customers out of service
- Reconfigure double circuit pole lines where both the normal and alternate source supply the same group of customers resulting in more than 1000 customers out of service.
- Arranging distribution feeders in order to give the best possible load balance on the system, by identifying feeders where load imbalance exceeds 50 amps between phases and considering improvements to reduce imbalance to less than 50 amps. (Guide page 7)
- Adding automatic sectionalizing devices to limit exposure to 500 customers or less per switchable zone. (Guide page 10)
- Using Age/Asset Health indexes in determining reliability risk for prioritizing upgrades. (Guide page 39)

Options on further improving reliability include:

- Consider options on creating and expanding system redundancy
- Improving on existing system redundancy for resiliency
- Examine and review feeder length

⁹² Eversource, Distribution System Engineering Guide, page 10

- Reduce existing and potential equipment materials vulnerability to nature

Eversource Distribution Planning Engineers follow the Guide for study procedures and project justifications. This document was last updated in 2020. Planning objectives outlined in the Guide include:⁹³

- Build sufficient capacity to meet instantaneous demand
- Satisfy power quality/voltage requirements within applicable standards
- Provide adequate availability to meet customer requirements
- Deliver power with required frequency
- Reach all customers wherever they exist

Planning and Operating Criteria

Conductor Loading: The Guide provides loading and voltage criteria with respect to applicable seasonal (Summer/Winter) ratings. Loading criteria for conductors are:

- Normal Rating - the maximum loading without incurring loss of life above the design-loading limit, and system changes are developed when limits are expected to exceed 100% during normal operation or 100% of cables during contingent operation (Guide page 6-7).
 - Feeder upgrades are required in the event that feeder ratings are being exceeded (Guide page 13).
- Emergency Rating – the maximum loading of overhead wires during contingent operation.

The Company's service territory comprises a range of both rural and urban areas that vary in electric supply characteristics and requirements. Electric distribution substations are diversified in size and redundancy in matching the difference in ratio between rural and urban areas. To maintain adequate levels of reserve capacity, power quality, and reliability, Bulk Distribution Substations are designed to sustain any Single Contingency (N-1) with no Load Loss. Specific transmission and distribution system considerations include:

- **Transmission System Considerations:** The transmission system supplying distribution bulk substations shall be designed so that the outcome of any single contingency event at the transmission side does not result in a condition greater than a Single Contingency (N-1) at the distribution bulk substation.
- **Distribution System Considerations:** The distribution system shall be designed so that any feeder outage does not result in thermal or voltage violation above design criteria.⁹⁴

⁹³ Eversource, Distribution System Engineering Manual, p. 4

⁹⁴ Eversource, Distribution System Engineering Manual, Sections 2.2 and 2.4., p. 10

Continuous development in reliability can result in system trade-offs. For instance, the overall cost for improvement may take several years to see the return in investment. Upgrading a line voltage could reduce line loss, but at the cost of increasing sensitivity to momentary interruptions and outages due to contact with vegetation.

Reliability Statistics offer methods for self-evaluation. Metrics defined in the IEEE 1366 include measurement for long-term performance of a system. These metrics include SAIFI, SAIDI and CAIDI. Metrics currently used by Eversource include SAIFI, SAIDI, CAIDI, Contribution to System SAIDI, and SAIDI minutes, which are defined below:

- SAIFI is the average number of sustained interruptions (defined by IEEE 1366 as an interruption lasting 5 minutes or more) per consumer during the year. It is the ratio of the annual number of interruptions to the total number of customers served.⁹⁵
- SAIDI indicates the total duration of interruption for the average customer during a predefined period of time (measured either in minutes or hours).⁹⁶
- CAIDI is expressed in minutes. It is the average time required (or experienced) to restore service to the average customer per sustained interruption CAIDI is the average restoration time. As with SAIDI, CAIDI can be used to calculate for different groups of customers from the whole system to parts of a feeder.⁹⁷
- Contribution to System SAIDI is the portion of SAIDI attributable to the customer–minutes of outage time that occurred on a particular part of the system (usually a circuit or a portion of a circuit) divided by the total number of customers served by the entire company (usually per state).⁹⁸
- SAIDI Minutes is the contribution to the SAIDI of a given unit (say a feeder or a district) contributed by a particular outage. It is the customer–minutes interrupted for the outage divided by the total number of customers in the given unit.⁹⁹

Figure 5-46 below shows that between 2011 through 2020, an overall reduction trend in SAIFI is a reflection of an overall reduction in outage events. Since 2011, there has been a significant reduction in SAIFI related to conductor/conductor equipment outages.

⁹⁵ IEEE, Standard 1366-2012 – IEE Guide for Electric Power Distribution Reliability Indices, 2012. <https://standards.ieee.org/standard/1366-2012.html>

⁹⁶ Ibid.

⁹⁷ Eversource, Distribution System Engineering Manual, Section 02.11

⁹⁸ Ibid.

⁹⁹ Ibid.

Figure 5-46. NH Eversource 2011 – 2020 SAIFI By Conductor / Conductor Equipment Outages

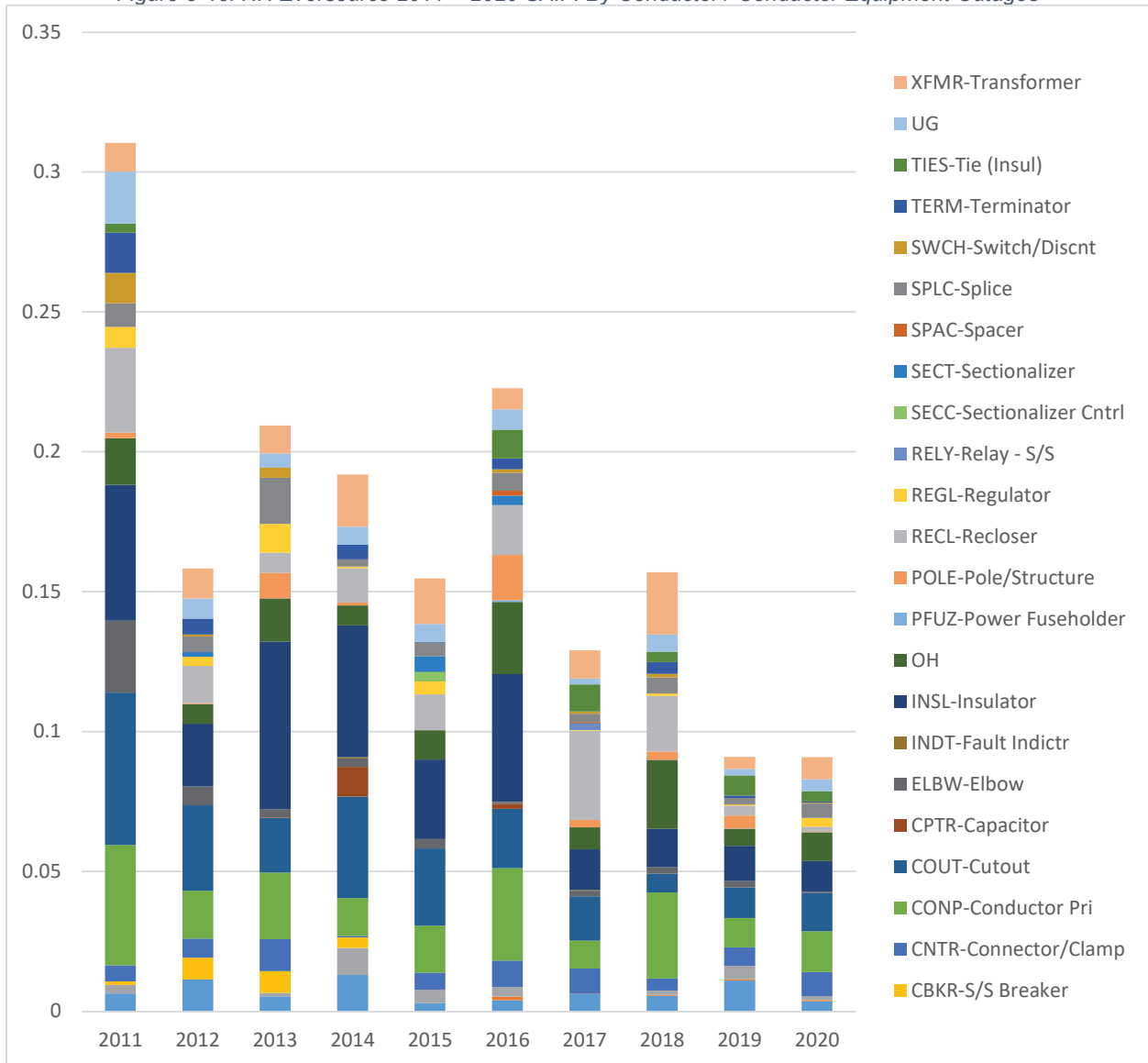

Source: Eversource internal data

Figure 5-47. NH Eversource 2011 – 2020 SAIDI By Conductor / Conductor Equipment Outages

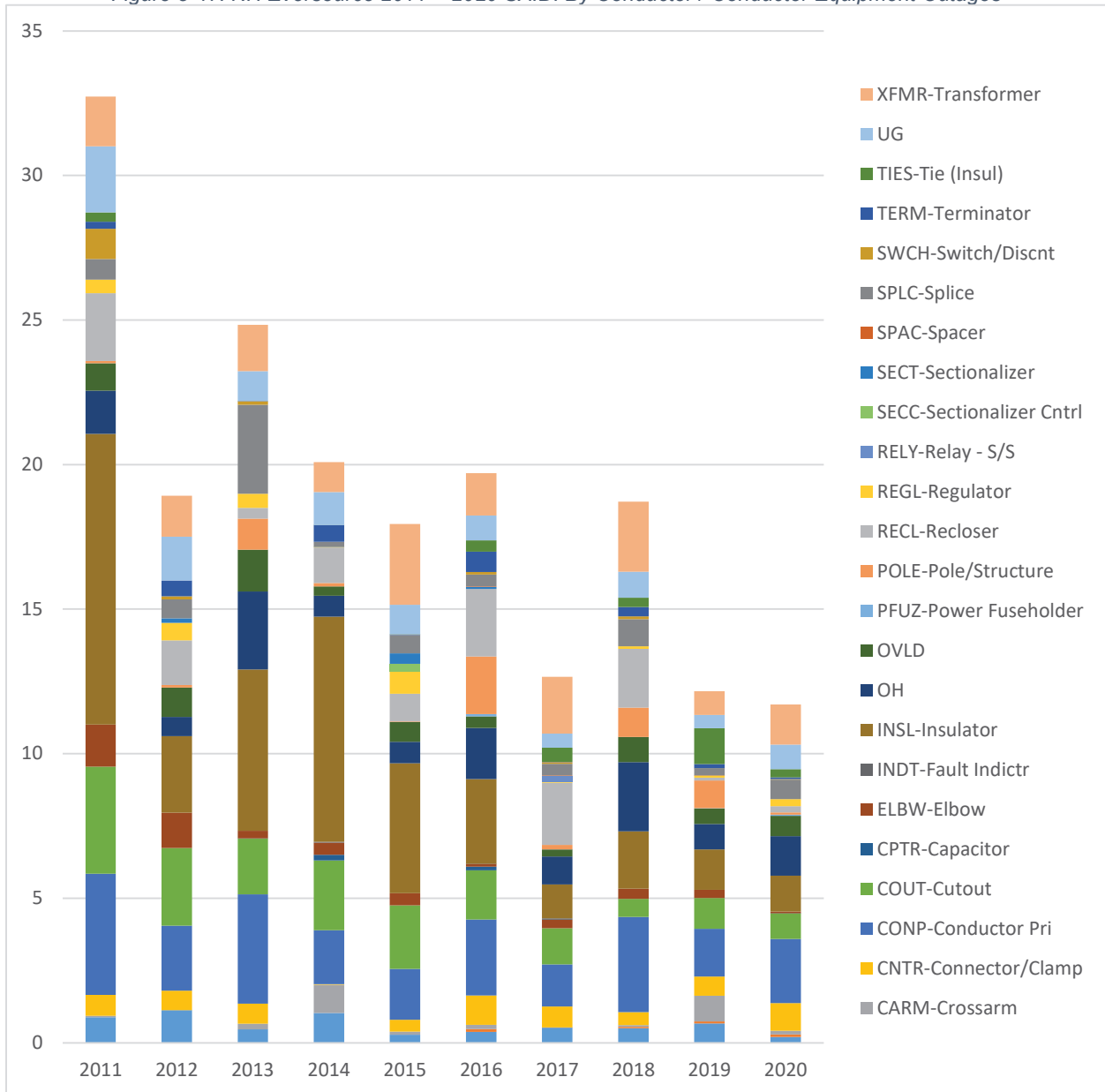

Source: Eversource internal data

When using SAIDI in calculating average duration for major events and catastrophic days (such as hurricanes and ice storms), this will lead to high SAIDI values since these types of events being that these are considered catastrophic events and therefore have a low probability of occurring. Large SAIDI values associated to these types of events can linger in a dataset for years causing an upshift in reliability metric trends (IEEE 1366-2012 page 19).

These metrics are designed to measure in seeing if a system is improving (or not improving) over time. They can also be used in recording major events or planned events separately, be

applied to specific equipment for a further insight on areas in need of consideration and can be used for comparing specific areas (system wide, feeder level, substation, etc.) for further insight on areas potentially in need of attention. Overall, the use of metrics administers a better understanding of the overall system health and performance.

The IEEE standard 1366-2012 explains that daily SAIDI values are preferred to daily SAIFI values because SAIDI values are a better measure of the total cost of reliability events, including utility repair costs and customer losses. The total cost of unreliability would be a better measure of the size of a major event, but collection of this data is not practical. (IEEE 1366-2012 page 22)

Duration-related costs of outages are higher than initial costs, especially for major events, which typically have long duration outages. Thus, a duration-related index will be a better indicator of total costs than a frequency-related index like SAIFI or MAIFI. Because CAIDI is a value per customer, it does not reflect the size of outage events. Therefore, SAIDI best reflects the customer cost of unreliability, and is the index used to identify Major Event Definitions (MEDs). SAIDI in minutes/day is the random variable used for MEDs. (IEEE 1366-2012 page 24).

Mitigations to Lower SAIDI/SAIFI

To mitigate the circuits with high SAIDI/SAIFI values, reconductoring or relocating a circuit can be considered. Eversource engineers have developed a data base for all circuits so that troublesome circuits can be addressed. Reconductoring should be with standard spacer cable construction. Other actions may include moving the circuits from forested areas in ROW to roadside when feasible.

Investments made towards relocating circuits to more accessible areas may create safer working conditions and allow the opportunity for updating aged facilities to current construction standards. In either case where relocation results in parallel to roadway or road-side construction, this allows for rapid restoration, straight forward trouble shooting, and simplified maintenance. This will improve resiliency, save time, money, and reduce overall length of outages. Overall expenditures in relocating facilities will develop a more robust and secure system that outweighs the potential costs and repercussions of operating and managing an aged system.

Analysis of the data in Figure 5-46 and Figure 5-47 allow for targeting existing problem areas in tracking improvements related to conductor and conductor equipment failures over a timespan where replacements may be made and further addressed wherever possible. The overall intention is to address equipment replacement where the most cost-effective impact can be made and continuing the trend until replacement based on cost effectiveness has been maximized.

Other reconductoring can be recommended due to increase loading when the load grows as found during annual studies. Reconductoring is also justified to increase capacity and to reduce line losses. Costs need to be considered to when providing this option as the cost can outweigh the benefit.

Conductor Size Selection

The conductor size selection problem involves determining the optimal conductor configuration for the distribution system, using a set of types of conductors. The objective is selection of conductor's size from the available size in each branch of the system which minimizes the sum of depreciation on capital investment and cost of energy losses and reliability while maintaining the voltages at different buses within the limits. Eversource has developed standard conductor sizes and types per General Section 05.131.

Outage Prevention

TRC recognizes Eversource is already in line with many good utility and industry operational and outage prevention practices. These include:

- Regular inspections and maintenance
- Veg management/tree trimming
- Animal guards
- Incorporating L/A's
- Thermal imaging inspection
- Use of Insulated wire (spacer or tree wire)
- Designing for proper transformer loading

System Operation

The way a system is built and operated can also have an impact on system reliability. This can include the types of equipment used for indicating faults, relay and recloser settings (duration or number of operations to close), fusing philosophy (fuse save, fuse blow, or hybrid) maintenance programs, and regular testing,

ROW and Maintenance

Having the ability to exercise and maintain rights-of-way and utility easements can further increase the effects of reliability, to include:

- Right to construct, maintain, operate, replace, upgrade, or rebuild pole lines or underground cable and appurtenances thereto
- Right of ingress and egress
- Right to trim and remove all trees on or adjacent easement necessary to maintain proper service
- Right to keep easement free of any structure or obstacle which deems a hazard to the line
- Right to prohibit excavation within 5 feet of any buried cable, or any change of grade which interferes with the cable

As engineers start their study process, they follow the Project Initiation Process below and develop their study models.

Figure 5-48. Eversource Project Initiation Process

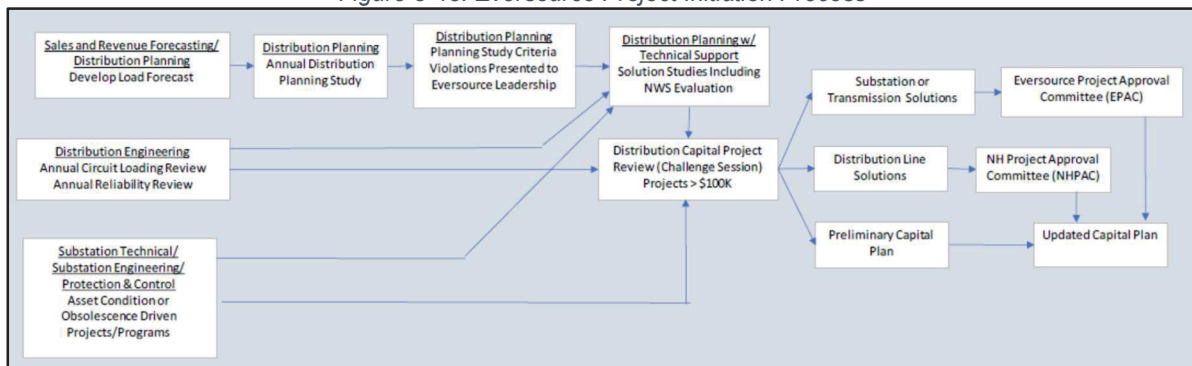

Source: Eversource

Model Development is a critical piece in the study process. Required models include summer or shoulder period minimum and peak load, as well as winter period minimum and peak load. The loads are extracted from GIS or other sources to get the loads for the substation or substations under study. Additionally, because of growing DER within the Eversource service area, engineers must factor in the Gross Load and DER on the system during the model development process. The Guide describes this in detail. From here, a Peak Forecast Load Model, Minimum Forecast Model, and Scenario Forecasts are developed for up to 10 years out.

Eversource historically produces both a ‘normal’ and an ‘extreme’ peak load forecast for each operating company. The normal peak load is based on average historical weather data, and the extreme peak is based on the 90th percentile of that historical weather data. The extreme peak is also referred to as a 90/10 forecast and it assumes a 10% chance that the peak load would be exceeded. Put another way, the forecast will be exceeded on average only once every 10 years.

After loads are determined, the Planning Model is developed using the GIS extraction and the study software to develop the load flow model with the current topology for the substation feeders. This includes the base case, probabilistic and standard load models, and 5- and 10-year yearly increase models.

Eversource conducts these studies on an annual basis for possible reporting to New Hampshire’s PUC. During the study, the engineer examines the following for each scenario.

- Substation Normal and Contingency
 - Distribution System Planning will use the Appropriate model to identify violations affecting Distribution Bulk Substations and backbone feeder sections involved in the calculation of the Substation Load Carrying Capability (LCC):
 - To identify violations under Normal (N-0) system conditions the Planning Base Case models will be used to verify that all substation transformers and backbone feeder sections operate under normal thermal ratings, voltage limits, and acceptable load phase balance, as per Section 2.2 of the Guide.

- To identify violations under Contingency (N-1) conditions the Planning Base Case models will be used, together with the guidance provided in Section 4.6 below to verify that all substation transformers and backbone feeders' sections operate under the appropriate Thermal Loading criteria specified in Section 2.2 of the Guide.
- Substation LCC Capability:
 - Distribution load transfer schemes used in the calculation of the LCC, will be modeled and verified by Distribution System Planning for Bulk Distribution Substations that fall within the following criteria:
 - Above 95% of nameplate under normal (N-0) conditions within the next 5 years
 - Above 95% of LCC under emergency (N-1) conditions within the next 5 years
- Contingency Conditions (N-1) Operational Assessment is conducted to determine if any criteria violations are found.
- Contingency Analysis
 - For Distribution Station in which LCC is equal to Firm:
 - For distribution stations where a single event at the transmission level corresponds to a single event at the distribution station, not exceeding N-1 conditions:
 - An N-1 contingency can be modeled at the distribution station by taking the largest transformer out of service and closing the appropriate bus breaker to transfer the load to the remaining transformers.
 - For distribution stations where a single event at the transmission level corresponds to an event at the distribution station that exceeds N-1 conditions:
 - The Distribution station contingency shall be modeled based on the transmission contingency that results in the worst contingency condition for the Distribution Station.
 - For Distribution Station in which LCC is not equal to Firm:
 - For distribution stations where a single event at the transmission level corresponds to a single event at the distribution station, not exceeding N-1 conditions. An N-1 contingency can be modeled at the distribution station by taking the largest transformer out of service and closing the appropriate bus breaker to transfer the load to the remaining transformers.
 - For distribution stations where a single event at the transmission level corresponds to an event at the distribution station that exceeds N-1 conditions. The Distribution station contingency shall be modeled based on the transmission contingency that results in the worst contingency condition for the Distribution Station.

Allowed System Adjustments to Mitigate Capacity and Power Quality Violations

Upon performing the study process, the probability for encountering criteria violations at the substation and feeder backbone level may include thermal, phase imbalance, and voltage, as outlined in Section 2.4 of the Guide. System improvements for addressing violations may include:

- Thermal violations:
 - Reduce load by load transfers or non-wires solution (as per Section 4.8 of the Guide).
 - Increase system capacity by upgrading existing equipment or installing new equipment.
 - Phase load imbalance: reduce phase loading by distribution circuit reconfiguration
 - Substation Secondary bus load thermal violations: reduce load by load transfer, or increase equipment capacity
 - Voltage Violation:
 - Reduce load by load transfers or non-wires solutions
 - Applying capacitor or voltage regulation.
 - Upgrading or installing new equipment

Finally, the engineer documents any system constraints with a detailed study report with the study findings. The report considers:

- The substation current configuration/capacity along with transformer ratings
- The historical peak and actual loads, actual/planned load transfers and most recent 10-year load forecast
- Assessment of DG connected to each transformer's feeders and any load adjustments made because of these facilities
- System Review Summary, including:
 - Identification of Non-Standard Bulk Distribution Substations and associated violations
 - Non-Bulk Distribution Substation configuration/capacity and potential violations
 - System reinforcements or mitigating measures to plan or investigate further

Based on the violation type (Capacity, Power Quality, and Reliability) the System Planning report should include:

- Substation name
- Substation Summary
- Description of Problem (if applicable)

- Description of Violation (if applicable)
- Substation Equipment Rating and Limit
- Actual Peak Load (Observed year)
- System Review Summary
- Possible Mitigation Actions

Solution Development

When the system capability does not meet forecasted loads, Planning Engineers must resolve projected violations prior to the violation year as per Section 4.8. Once a list of violations is compiled, Distribution System Planning engineers will identify potential solutions to address those violations affecting:

- Bulk Distribution Substations
- Non-Bulk Distribution Substation
- Feeder Backbone Sections required for substation LCC capacity

The solution development method adopted by Eversource is a complex and iterative process which addresses the system needs in conjunction with the capital budget. This approach balances the safe and reliable service provided by the Company with the need to control cost for their customers. The solutions may include the following:

- Distribution Bulk Substation Solution Development
- Distribution Feeder and Non-Bulk Substation Solution Development
- Application of Non-Wires Solutions (NWS)
 - The process for identifying NWS is complicated and the steps are listed in the Guide.

Planned and Proposed Upgrades

During the annual development of the transmission and distribution capacity and power quality plans, Eversource shall design long term solutions (Traditional and NWS) that will address capacity and resiliency needs of all distribution substations. Planned projects, identified in the Low Load and Medium Load Planning Scenarios, that address immediate substation capacity and resiliency needs shall be designed and prioritized to be included in the 5-year capital plan as approved projects. Proposed projects, identified in the Long-Term Planning Scenario, that address long term capacity and resilience needs shall be developed but not submitted for approval. Figure 5-49 provides a high-level breakdown for an ideal project planning schedule.

Figure 5-49. Eversource Project Planning Schedule

Constraint Type	Timeframe	Status	Planning Scenario
Planned	1-5 years	Full development & approval	Low and Medium Load Growth
Planned	5 -10 years	Partially developed	Medium and High Load Growth
Proposed	10 years and above	Conceptual Design	Medium and High Load Growth

Relocation Project Example:

Newport Circuit 317/3410 was originally built in 1937 and has maintained many of its original poles, crossarms, insulators, and conductor. A large portion of 317/3410 has been budgeted for 2021-2025 to remove the line from its existing ROW and relocated adjacent to the roadside with construction starting in 2021. Approximate cost is \$1M/mi to rebuild with steel poles and spacer cable. Figure 5-50 shows the line as is today in standing water.

Figure 5-50. Eversource Line 317 Line Relocation



Source: TRC Field Inspection

Reconductoring with spacer cable example

Circuit 3139X had multiple tree related outage and was a poor performing circuit. A capital project was implemented to improve the circuit backbone which included upgrading 3.5 miles of open wire conductor in Heather-lite configuration to covered spacer cable along Highway 63. There were six distribution automation devices installed, all with single phase tripping. There was also a distribution automation device installed just outside of Chestnut Hill Substation to create single phase tripping capability. Following the completion of this work, circuit reliability improved. Figure 5-51 displays a completed segment of the circuit backbone.

Figure 5-51. Eversource Line Reconductored to Spacer Cable



Source: Eversource

Figure 5-52. Eversource Line Reconductored to Spacer Cable

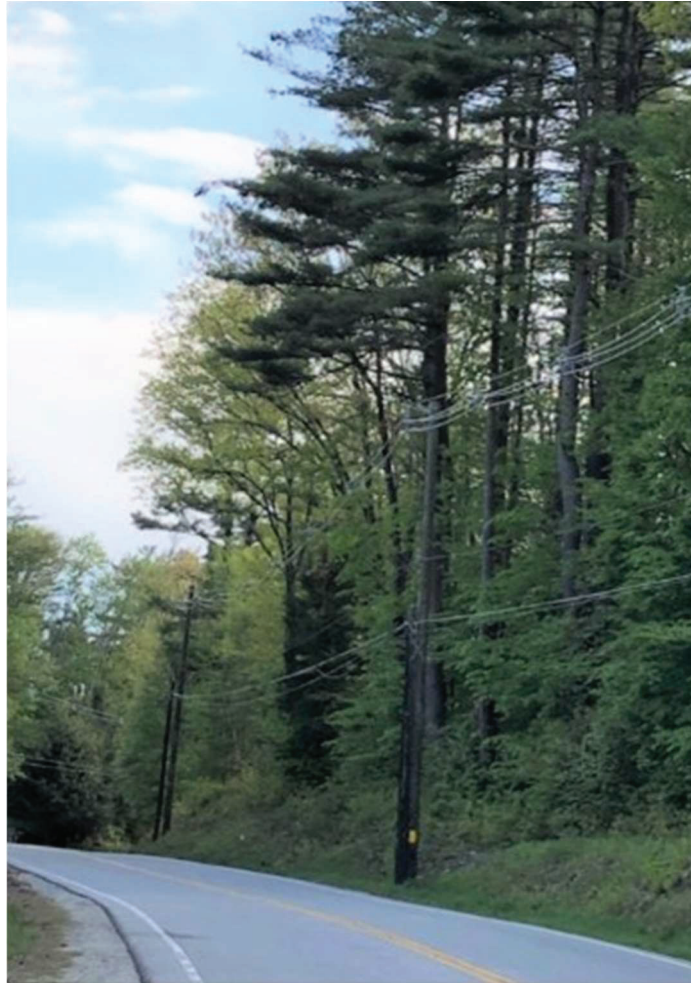

Source: Eversource

Cost Analysis

TRC evaluated the Eversource project justification processes listed in the Guide’s references in section 1, which notes that “Projects that are required within the next 6 years of the Observed Year should be fully developed and approved using the latest version of the Capital Project Approval Process, refer to Section 7.1. A Distribution System Planning Substation Review form should be completed by the responsible System Planning Engineer.”

TRC found the project costs to be within industry standards, and from the documentation presented, TRC did not observe evidence of project scope changes due to consecutive reviews.

Recommendations

TRC recommends Eversource set up a tracking program to compare historical outage data for line segments for 3-5 years (as data is available) and then report annually on that segment post-

improvement. Such a system will document the improved reliability and resiliency delivered by relocation and reconductoring projects. TRC recommends reducing the number of radial feeds to allow for increased networking and load pickup throughout the system. Eversource should also maintain awareness for project cost increases that may arise as projects are delayed.

6. Conclusion and Summary of Recommendations

This section summarizes TRC's findings for the Eversource distribution system assessment and aggregates the study recommendations across the topic areas surveyed in this research. Finally, TRC presents areas for potential future research based on the research and findings.

6.1 Summary of Findings

Eversource's recent or proposed enhanced standards and activities for distribution system hardening have been designed to maintain and improve the reliability and resiliency of the distribution system. These changes are driven by an increased recurrence of major storm events since 2008 that have caused prolonged and widespread outages, at times impacting over 40% of customers. The proposed investments in a more resilient system align with a growing trend among utilities around the country that have faced similar weather (or other external) threats to their operations. It is important to not view individual standards or activities targeted toward resiliency or reliability in isolation, but rather as a package of tools that can be deployed when rebuilding or when making targeted improvements to the system.

Below are key findings related to each of the components of this distribution system assessment research:

Industry Resiliency Planning

As noted above, the utility industry is grappling with the need for accelerated planning and investments in resiliency, driven by climate-change induced increases in severe weather events. Despite the increase in interest and planning around resiliency, few utilities or regulators have developed a clear path to plan for costs and benefits, given the low-frequency, high-impact nature of resiliency-focused major events. These and other key findings include:

- Increased resiliency and hardening investment and planning activity across most states is driven by an increase in severe weather events that can significantly impact outage durations.
- Resiliency planning frameworks stress assessment of local climate risks to identify tailored solutions for each utility.
- Evaluating cost-effectiveness of resiliency investments remains a critical challenge for utilities and regulators, as the benefits are difficult to monetize.
- Shifts in the traditional utility business model are impacting investment decisions. The move away from a cost-plus ratemaking approach and moving to a performance-based structure (e.g., New York and Massachusetts) has allowed regulators to incorporate metrics around grid hardening and provides greater flexibility to utilities in their system investment.
- Cost recovery remains central to the ongoing industry debate. This research identifies various approaches currently being advanced, presented later in this chapter. These approaches demonstrate the range in considerations and fragmented nature of the responses across the country.

System Condition

Key findings related to the overall condition of Eversource New Hampshire's electric distribution system include:

- A substantial number of wood poles, primary conductor circuits, substation breakers and substation transformers are at the end of their useful life.
- Wood poles are physically overloaded due to their age and number of attachments.
- Many circuit lines in the ROW are inaccessible, due to their locations, and difficult to maintain.
- Trees and canopy are in close proximity to the distribution system, making the lines vulnerable.

Steel Poles

Eversource has specified the use of steel poles in the off-road right-of-way due to the difficulties in accessing these line sections in the event of a failure. Steel poles are stronger, less prone to catastrophic failure, lighter and thus easier to deploy, and require less maintenance than their wood counterparts. Key findings include:

- A number of utilities, including several in the South and West have implemented steel poles as the standard for distribution construction. Eversource has used steel structures in the ROW for many years.
- The useful lifespan of a steel pole is estimated to be twice as long as a wood pole.
- While upfront costs can be 250-400% higher for steel poles, the total lifecycle cost of steel poles is lower due to the escalation in material and installation costs of wood poles that must be replaced sooner than a steel pole.

Class 2 Wood Poles

Eversource has implemented a standard of using stronger Class 2 wood poles, instead of Class 3 or 4, for distribution primary poles due to the ability to better withstand wind, ice, and other severe weather events. Eversource designed its stands to meet NESC guidelines for severe wind and ice loading. Key findings include:

- Pole failure is the least desirable outcome in an outage event due to the cost and complexity in repairing (compared to failure of conductor, crossarms, or other components).
- Class 2 wood poles, with a wider circumference, can withstand 60% greater force than smaller, Class 4 poles.
- Installed costs of Class 2 wood poles are marginally (2-4%) higher than the cost of a comparable Class 3 wood pole.

Spacer Cable

Eversource has made spacer cable its standard for three-phase primary distribution as part of resiliency guidelines to reduce faults from tree and animal contact and survive larger tree strike. Key findings include:

- In addition to ability to withstand tree and animal interference, spacer cable requires less clearance than open wire, reducing ROWs and vegetation management requirements.
- Spacer cable costs approximately 200% more than open wire per mile installed, with higher costs equally driven by labor, materials, and overhead costs.

Fiberglass Crossarms

Similar to the components listed above, Eversource has standardized the use of fiberglass crossarms for new construction or replacements as needed. This standardization was driven by the improved longevity, strength, and predictability of fiberglass components considering increasing severe weather events.

Key findings include:

- Modeling shows that fiberglass cross arms pass the heaviest ice loading with heavy tree contact and high wind test simulations where wood crossarms failed.
- Fiberglass crossarms are commonly paired with steel distribution poles, given both have superior longevity to wood material equipment.
- Fiberglass crossarms weigh one-third as much as equivalent wood cross arms and do not require braces, making installation of fiberglass crossarms easier.
- The lifecycle costs of dead-end and tangent fiberglass crossarms are 38-44% of the total lifecycle costs of wood crossarms, due to the need for replacing a wood crossarm at 25-30 years.

Vegetation Management

Eversource operates a portfolio of vegetation management activities designed to reduce high-risk vegetation around lines (ETT, ETR, and ROW) and then maintain improved clearances through regular 5-year maintenance (SMT). Key findings include:

- Vegetation management activities since 2011 have led to a significant improvement in tree related SAIFI and SAIDI performance. Inside-zone caused outages have been reduced tenfold for both SAIDI and SAIFI, while outside-zone caused outages have trended slightly downward over the last decade.
- Modeling shows that reductions in vegetation management spending can lead to a disproportionate increase in cycle-time to return to each circuit. For example, a 20% reduction in spending can nearly double the cycle from 5 to 9 years.
- Similarly, deferring SMT can lead to increased costs per mile. A 1-year delay can increase per-mile costs by 20%, while a 3-year deferral can increase costs by 51%.

Substation Transformers

Eversource has designed criteria for designing substation components to minimize length and impacts of outages during contingency events. Key findings include:

- Standardizing substation transformer sizes can provide benefits for streamlining inventory and reducing event response time.

Distribution Planning

Eversource conducts distribution planning to maintain system operations within established operating criteria. Key findings include:

- Engineers develop solutions to address capacity, power quality, and reliability concerns based on historical performance data and forward-looking forecasts.
- Line relocation and reconductoring are two options to address reliability issues.

6.2 Recommendations

TRC recommends the following practices, based on the research and findings of this assessment:

- 1) Consolidate current resiliency/hardening efforts into an overarching program following the decision framework outlined by the Department of Energy.
- 2) Establish a systematic asset replacement program to replace wood poles on an age basis, that support three phase lines, over the next 5 years. Beginning with poles 70 years and older poles, with priority on the smaller class 4, 5 and below, then address the 60- and 50-year-old poles. There are about 42,000 wood poles aged 50 years and older that will need to be identified and prioritized for replacement. It is estimated that 20% (8,400) of those poles support three phase lines, requiring approximately 1,700 poles/year of the poles in this age group be replaced in conjunction with the other pole replacement efforts.
- 3) Poles that are identified as structurally loaded at 90% or greater, be replaced with the correct sized poles to carry the mechanical load under the mandated NESC design conditions. To accomplish this, TRC also recommends that 10% (approx. 4,500) of the overloaded poles, be replaced on an annual basis. Priority should be given to the poles that are overloaded by the greatest amount and/or most critical to the system. It is also essential that all new poles that are installed have pole loading analysis completed to ensure the design criteria is met. Individual pole loading analysis will need to be performed on all new and replacement corner, junction, and dead-end poles. Typical tangent pole analysis can be modeled to promote efficient design.
- 4) Continue the practice to use a minimum of Class 2 wood poles for all applications and ensure that NESC pole loading requirements are met for both the heavy loading and extreme wind scenarios. Based on analysis of the representative data, Class 2 wood poles are half as likely to be overloaded with attachments compared to Class 3 poles.
- 5) Identify candidate lines for ROW line relocation to roadside and develop a multi-year plan to address the most critical and least accessible lines. The plan needs to coordinate with efforts to reconductor open wire to spacer cable and the overloaded and aged pole projects.
- 6) Increase vegetation management and spacer cable installation for vulnerable lines.

- 7) For distribution engineering materials and equipment, Eversource should continue to plan reliability and hardening standards and investments from a system perspective, rather than a series of individual components:
 - a) Given lower lifecycle costs and difficulty patrolling and replacing more remote ROW assets in the event of a failure, continue to use steel poles as the standard in these environments when not able to move roadside.
 - b) Continue to use Class 2 wood distribution poles for the added strength in high wind and ice loading scenarios. Perform pole loading analysis on all new and replacement corner, junction, and dead-end poles, to ensure the design criteria is met.
 - c) TRC recommends adding a proactive program to replace wood poles or obsolete steel lattice towers in the ROW with steel poles on a planned basis. The plan should include a minimum of five circuit-miles of off-road ROW, three phase rebuilds, including rebuilds that are part of the inaccessible line relocation projects. Line projects need to be prioritized by reliability performance and susceptibility to damage or failure from trees.
 - d) Follow the spacer cable program as outlined in the Eversource 2016 Resiliency Guidelines. As part of the capital planning process, accelerate the rebuilding/reconductoring of the open wire, three phase lines that are the most susceptible to outages in heavily treed and narrow ROW areas over the next 5-years. Work in conjunction with the inaccessible line relocations to the roadside and steel pole installation projects in the steel pole section.
 - e) Continue to use fiberglass crossarms as specified, given their longevity, improved strength, and resulting lower lifecycle costs. These components also pair better with the proposed use of steel poles due to similar useful lives.
- 8) Vegetation Management:
 - a) For SMT, address an average 2,440 miles annually to follow the 60-month clearing cycle. This will focus on the Inside Zone vegetation and maintain the level of tree caused outages at current levels as indicated by Figure 5-23. Deferral of this work for a year or more will risk erasing the progress on tree-related reliability improvements achieved over the last decade and lead to increasing costs per mile and physical resource needs. This will likely have an impact on the budget.
 - b) Accelerate ETT to 80 miles per year to address the remaining 500 miles of the backbone circuits within the next seven years. This will likely have an impact on the budget and be subject to availability of physical resources.
 - c) Continue ROW clearing at the current pace to allow for the restoration of the full original easement where vegetation has encroached.
 - d) For ETR, target approximately 19,000 hazard tree removals annually following the current identification and prioritization practice. Evaluate additional strategies to drive improvements in outside-zone tree-related outage performance.
- 9) Standardize substation transformer sizes wherever possible based on voltage class to allow for greater efficiency in maintaining stock of fewer transformer sizes and flexibility in responding to contingency events and coordination with neighboring state service areas.

-
- 10) Establish a tracking program to compare historical outage data for line segments for 3-5 years (as data is available) and then report annually on that segment post-improvement. Such a system will document the improved reliability and resiliency delivered by relocation and reconductoring projects.
 - 11) Continue to reduce the number of radial feeds to allow for increased networking and load pickup throughout the system.
 - 12) Maintain awareness for distribution project cost increases that may arise as projects are delayed.